

## ROTOFIX 32 A



Ⓝ DE	Bedienungsanleitung .....	5
Ⓝ EN	Operating Instructions .....	18
Ⓝ FR	Mode d'emploi .....	30
Ⓝ IT	Istruzioni per l'uso .....	43

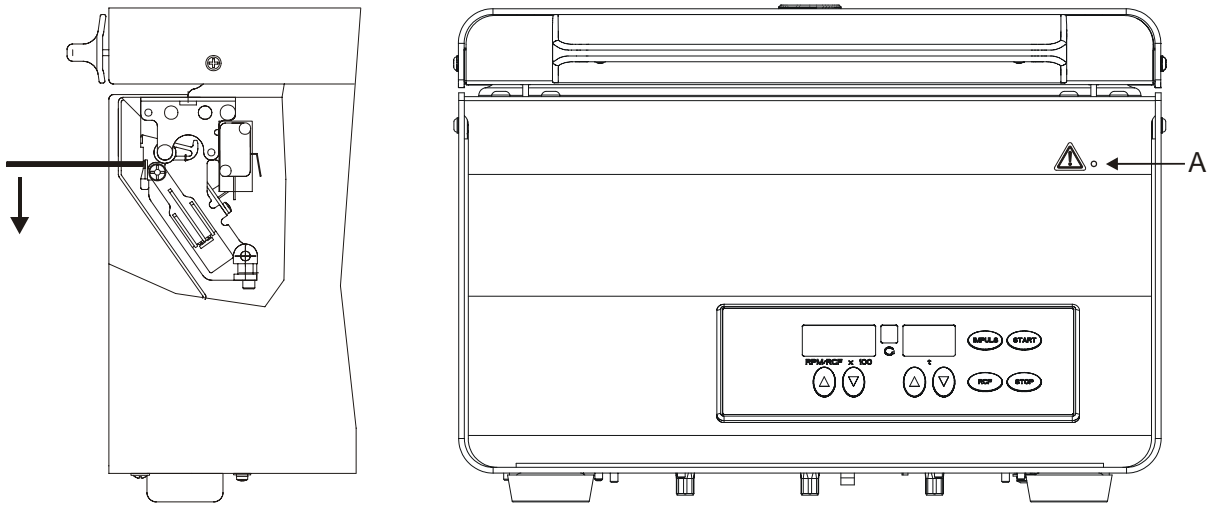

Fig. 1

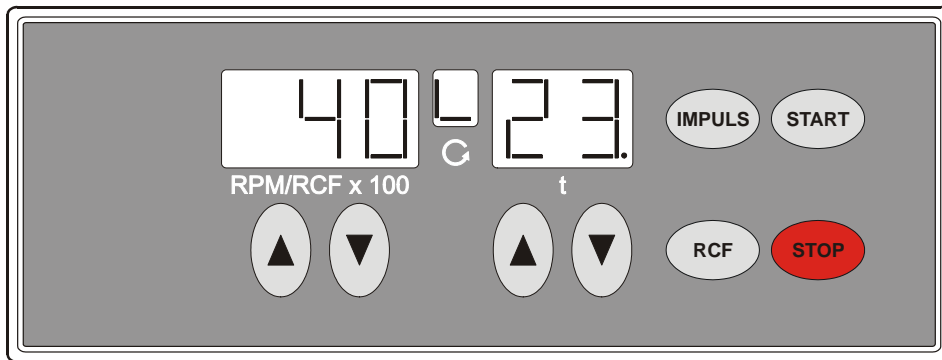

Fig. 2 ROTOFIX 32 A



**EG-Konformitätserklärung  
EC Conformity Declaration  
Déclaration de conformité CE  
Dichiarazione di conformità alle norme CEE**

Andreas Hettich GmbH & Co. KG • Föhrenstraße 12 • D-78532 Tuttlingen • Germany

Das bezeichnete Gerät, inklusive Zubehör entspricht den aufgeführten EG-Richtlinien und Normen.  
The denoted device, including accessories corresponds to the listed EC guidelines and standards.  
L'appareil désigné, y compris les accessoires, correspond aux directives CE et aux normes énumérées.  
L'apparecchio designato, compresi gli accessori, è conforme alle direttive CE e alle norme citate.

Geräteart, Type of device, Type d'appareil, Tipo di apparecchio:

**Laborzentrifuge mit Zubehör, Laboratory centrifuge with accessories, Centrifugeuse de laboratoire avec des accessoires, Centrifuga da laboratorio con accessori**

Typenbezeichnung, Type designation, Désignation de modèle, Contrassegno tipo:

**ROTOFIX 32 A**

EG-Richtlinien/Normen, EC guidelines/standards, Directives CE/Normes, Direttive/Norme CEE:

**73/23/EWG, EN 61010-1, EN 61010-2-020**

**89/336/EWG + 92/31/EWG + 93/68/EWG, EN 61000-6-1, EN 55011, EN 61000-3-2, EN 61000-3-3**

**98/37/EG, EN ISO 12100-1, EN ISO 12100-2**

**98/79/EG**

Tuttlingen, 10.12.2007

H. Eberle



---

**Andreas Hettich GmbH & Co. KG**  
**Föhrenstraße 12, D-78532 Tuttlingen / Germany**  
**Phone +49 (0)7461 / 705-0**  
**Fax +49 (0)7461 / 705-125**  
**info@hettichlab.com, service@hettichlab.com**  
**www.hettichlab.com**

© 2006 by Andreas Hettich GmbH & Co. KG

All rights reserved. No part of this publication may be reproduced without the prior written permission of the copyright owner.

Änderungen vorbehalten! , Modifications reserved! , Sous réserve de modifications ! , Con riserva di modifiche!

**AB1206DEENFRIT / 12.07**

## Inhaltsverzeichnis

1	Bestimmungsgemäße Verwendung .....	6
2	Restrisiken .....	6
3	Technische Daten .....	6
4	Sicherheitshinweise .....	7
5	Bedeutung der Symbole .....	8
6	Lieferumfang .....	8
7	Auspacken der Zentrifuge .....	8
8	Inbetriebnahme .....	8
9	Deckel öffnen und schließen .....	9
9.1	Deckel öffnen .....	9
9.2	Deckel schließen .....	9
10	Ein- und Ausbau des Rotors .....	9
11	Beladen des Rotors .....	9
12	Bedien- und Anzeigeelemente .....	10
12.1	Symbole des Bedienfeldes .....	10
12.2	Tasten und Einstellmöglichkeiten .....	10
13	Bremsstufe einstellen .....	11
14	Zentrifugerradius einstellen .....	11
15	Zentrifugation .....	11
15.1	Zentrifugation mit Zeitvorwahl .....	12
15.2	Dauerlauf .....	12
15.3	Kurzzeitzentrifugation .....	12
15.4	Anzeige der relativen Zentrifugalbeschleunigung (RCF) .....	12
16	Relative Zentrifugalbeschleunigung (RCF) .....	13
17	Zentrifugation von Stoffen mit höherer Dichte .....	13
18	Rotor-Erkennung .....	13
19	Notentriegelung .....	13
20	Pflege und Wartung .....	14
20.1	Zentrifuge .....	14
20.2	Rotoren und Zubehör .....	14
20.2.1	Tragzapfen .....	14
20.2.2	Rotoren und Zubehör mit begrenzter Verwendungsdauer .....	14
20.3	Autoklavieren .....	15
20.4	Zentrifugiergefäße .....	15
21	Störungen .....	16
22	Netzeingangssicherungen wechseln .....	17
23	Reparaturannahme von Zentrifugen .....	17
24	Entsorgung .....	17
25	Anhang / Appendix .....	56
25.1	Rotoren und Zubehör / Rotors and accessories .....	56

## 1 Bestimmungsgemäße Verwendung

Bei der vorliegenden Maschine handelt es sich um ein Medizinprodukt (Laborzentrifuge) im Sinne der IVD-Richtlinie 98/79/EG. Die Zentrifuge dient zum Trennen von Stoffen bzw. Stoffgemischen mit einer Dichte von max. 1,2 kg/dm<sup>3</sup>. Darunter fallen auch Stoffe und Stoffgemische menschlichen Ursprungs. Die Zentrifuge ist nur für diesen Verwendungszweck bestimmt. Eine andere oder darüber hinausgehende Benutzung gilt als nicht bestimmungsgemäß. Für hieraus entstehende Schäden haftet die Firma Andreas Hettich GmbH & Co. KG nicht.

Zur bestimmungsgemäßen Verwendung gehört auch das Beachten aller Hinweise aus der Bedienungsanleitung und die Einhaltung der Inspektions- und Wartungsarbeiten.

## 2 Restrisiken

Die Maschine ist nach dem Stand der Technik und den anerkannten sicherheitstechnischen Regeln gebaut. Bei unsachgemäßer Verwendung und Behandlung können Gefahren für Leib und Leben des Benutzers oder Dritter bzw. Beeinträchtigungen an der Maschine oder an anderen Sachwerten entstehen. Die Maschine ist nur für die bestimmungsgemäße Verwendung, und nur in sicherheitstechnisch einwandfreiem Zustand zu benutzen.

Störungen, die die Sicherheit beeinträchtigen können, sind umgehend zu beseitigen.

## 3 Technische Daten

Hersteller	Andreas Hettich GmbH & Co. KG D-78532 Tuttlingen	
Modell	ROTOFIX 32 A	
Typ	1206	1206-01
Netzspannung ( $\pm 10\%$ )	208 – 240 V 1~	100 – 127 V 1~
Netzfrequenz	50 – 60 Hz	50 – 60 Hz
Anschlusswert	300 VA	300 VA
Stromaufnahme	1.4 A	3.0 A
Kapazität max.	4 x 100 ml / 32 x 15 ml	
zulässige Dichte	1.2 kg/dm <sup>3</sup>	
Drehzahl (RPM)	6000	
Beschleunigung (RCF)	4186	
Kinetische Energie	3160 Nm	
Prüfpflicht (BGR 261)	nein	
Umgebungsbedingungen (EN 61010-1)	<p>nur in Innenräumen bis zu 2000 m über Normal-Null 2°C bis 40°C</p> <p>maximale relative Luftfeuchte 80% für Temperaturen bis 31°C, linear abnehmend bis 50% relativer Luftfeuchte bei 40°C.</p>	
– Aufstellungsort		
– Höhe		
– Umgebungstemperatur		
– Luftfeuchtigkeit		
– Überspannungskategorie (IEC 60364-4-443)	II	
– Verschmutzungsgrad	2	
Geräteschutzklasse	I	
nicht für den Einsatz in explosionsgefährdeter Umgebung geeignet.		
EMV		
– Störaussendung (Funkentstörung)	EN 55011, Gruppe 1, Klasse B EN 61000-3-2 EN 61000-3-3	FCC Class B
– Störfestigkeit	EN 61000-6-2	----
Geräuschpegel (rotorabhängig)	$\leq 57$ dB(A)	
Abmessungen		
– Breite	366 mm	
– Tiefe	430 mm	
– Höhe	257 mm	
Gewicht	23 kg	

#### 4 Sicherheitshinweise



**Bei Nichteinhaltung dieser Hinweise kann beim Hersteller kein Gewährleistungsanspruch geltend gemacht werden.**

- **Vor Inbetriebnahme der Zentrifuge ist die Bedienungsanleitung zu lesen und zu beachten. Nur Personen, die die Bedienungsanleitung gelesen und verstanden haben, dürfen das Gerät bedienen.**
- Neben der Bedienungsanleitung und den verbindlichen Regelungen der Unfallverhütung sind auch die anerkannten fachtechnischen Regeln für sicherheits- und fachgerechtes Arbeiten zu beachten. Die Bedienungsanleitung ist um Anweisungen aufgrund bestehender nationaler Vorschriften des Verwenderlandes zur Unfallverhütung und zum Umweltschutz zu ergänzen.
- Die Zentrifuge ist nach dem Stand der Technik gebaut und betriebssicher.
  - Es können aber von ihr Gefahren für den Benutzer oder Dritte ausgehen, wenn sie nicht von geschultem Personal oder unsachgemäß oder zu nicht bestimmungsgemäßigem Gebrauch eingesetzt wird.
- Die Zentrifuge ist so aufzustellen, dass sie standsicher betrieben werden kann.
- Vor Benutzung der Zentrifuge unbedingt den Rotor auf festen Sitz prüfen.
- Während eines Zentrifugationslaufes dürfen sich gemäß IEC 61010-2-020, in einem Sicherheitsbereich von 300 mm um die Zentrifuge herum, keine Personen, Gefahrstoffe und Gegenstände befinden.
- Die Zentrifuge darf während des Betriebs nicht bewegt oder angestoßen werden.
- Im Störfall bzw. bei der Notentriegelung nie in den sich drehenden Rotor greifen.
- Um Schäden durch Kondensat zu vermeiden, muss bei Wechsel von einem kalten in einen warmen Raum die Zentrifuge entweder mindestens 3 Stunden im warmen Raum aufwärmen bevor sie an das Netz angeschlossen werden darf oder 30 Minuten im kalten Raum warmlaufen.
- Es dürfen nur die vom Hersteller für dieses Gerät zugelassenen Rotoren und das zugelassene Zubehör verwendet werden (siehe Kapitel "Anhang/Appendix, Rotoren und Zubehör/Rotors and accessories").
- Der Rotor der Zentrifuge darf nur entsprechend dem Kapitel "Beladen des Rotors" beladen werden.
- Bei der Zentrifugation mit maximaler Drehzahl darf die Dichte der Stoffe oder Stoffgemische  $1,2 \text{ kg/dm}^3$  nicht überschreiten.
- Zentrifugationen mit unzulässiger Unwucht sind nicht erlaubt.
- Die Zentrifuge darf nicht in explosionsgefährdeter Umgebung betrieben werden.
- Eine Zentrifugation mit:
  - brennbaren oder explosiven Materialien
  - Materialien, die chemisch mit hoher Energie miteinander reagieren ist verboten.
- Bei der Zentrifugation von gefährlichen Stoffen bzw. Stoffgemischen, die toxisch, radioaktiv oder mit pathogenen Mikroorganismen verseucht sind, sind durch den Benutzer geeignete Maßnahmen zu treffen. Es müssen grundsätzlich Zentrifugiergefäße mit speziellen Schraubverschlüssen für gefährliche Substanzen verwendet werden. Bei Materialien der Risikogruppe 3 und 4 ist zusätzlich zu den verschließbaren Zentrifugiergefäßen ein Bio-Sicherheitssystem zu verwenden (siehe Handbuch "Laboratory Biosafety Manual" der Weltgesundheitsorganisation).  
Bei einem Bio-Sicherheitssystem verhindert eine Bioabdichtung (Dichtring) zwischen Gehänge und Deckel das Austreten von Tröpfchen und Aerosolen.  
Wird das Gehänge eines Bio-Sicherheitssystems ohne den Deckel verwendet, muss der Dichtring vom Gehänge entfernt werden, um eine Beschädigung des Dichtrings während des Zentrifugationslaufes zu vermeiden. Beschädigte Dichtringe dürfen nicht mehr zum Abdichten des Bio-Sicherheitssystems verwendet werden. Ohne Verwendung eines Bio-Sicherheitssystems ist eine Zentrifuge im Sinne der Norm EN 61010-2-020 nicht mikrobiologisch dicht.  
Lieferbare Bio-Sicherheitssysteme siehe Kapitel "Anhang/Appendix, Rotoren und Zubehör/Rotors and accessories". Im Zweifelsfall sind entsprechende Informationen beim Hersteller einzuholen.
- Der Betrieb der Zentrifuge mit stark korrodierenden Stoffen, welche die mechanische Festigkeit von Rotoren, Gehängen und Zubehörteilen beeinträchtigen können, ist nicht erlaubt.
- Rotoren, Gehänge und Zubehörteile, die starke Korrosionsspuren oder mechanische Schäden aufweisen, oder deren Verwendungsdauer abgelaufen ist, dürfen nicht mehr verwendet werden.
- Reparaturen dürfen nur von einer vom Hersteller autorisierten Person ausgeführt werden.
- Es dürfen nur Originalersatzteile und zugelassenes Originalzubehör der Firma Andreas Hettich GmbH & Co. KG verwendet werden.
- Es gelten die folgenden Sicherheitsbestimmungen:  
IEC 61010-1 und IEC 61010-2-020 sowie deren nationalen Abweichungen.
- Die Sicherheit und Zuverlässigkeit der Zentrifuge ist nur dann gewährleistet, wenn:
  - die Zentrifuge nach der Bedienungsanleitung betrieben wird.
  - die elektrische Installation, am Aufstellungsort der Zentrifuge, den Anforderungen von IEC Festlegungen entspricht.
  - vorgeschriebene Prüfungen nach BGV A1, BGR 261 durch einen Sachkundigen durchgeführt werden.

## 5 Bedeutung der Symbole



Symbol an der Maschine:

Achtung, allgemeine Gefahrenstelle.

Vor Benutzung der Zentrifuge unbedingt die Bedienungsanleitung lesen und die sicherheitsrelevanten Hinweise beachten!



Symbol in der Bedienungsanleitung:

Achtung, allgemeine Gefahrenstelle.

Dieses Symbol kennzeichnet sicherheitsrelevante Hinweise und deutet auf mögliche gefährliche Situationen hin.

Das Nichtbeachten dieser Hinweise kann zu Sach- und Personenschäden führen.



Symbol in der Bedienungsanleitung:

Dieses Symbol deutet auf wichtige Sachverhalte hin.



Symbol an der Maschine und in der Bedienungsanleitung:

Symbol für die getrennte Sammlung von Elektro- und Elektronikgeräten, gemäß der Richtlinie 2002/96/EG (WEEE). Das Gerät gehört zur Gruppe 8 (Medizinische Geräte).

Verwendung in den Ländern der Europäischen Union sowie in Norwegen und der Schweiz.

## 6 Lieferumfang

Folgendes Zubehör wird mit der Zentrifuge geliefert:

- |   |                                 |
|---|---------------------------------|
| 1 | Anschlusskabel                  |
| 2 | Sicherungen                     |
| 1 | Schmierfett für Tragzapfen      |
| 1 | Sechskantstiftschlüssel         |
| 1 | Entriegelungsstift              |
| 1 | Hinweisblatt Transportsicherung |
| 1 | Bedienungsanleitung             |

Rotor(en) und das entsprechende Zubehör werden je nach Bestellung mitgeliefert.

## 7 Auspacken der Zentrifuge

- Den Karton nach oben abheben und die Polsterung entfernen.

- Nicht an der Griffleiste des Deckels anheben.  
Das Gewicht der Zentrifuge beachten, siehe Kapitel "Technische Daten".

Die Zentrifuge, mit der angemessenen Anzahl von Helfern, an beiden Seiten anheben und auf den Labortisch stellen.

## 8 Inbetriebnahme

- Gemäß der Laborgerätenorm IEC 61010-2-020 muss in der Gebäudeinstallation ein Notausschalter zur Trennung der Netzversorgung im Fehlerfall angebracht sein. Dieser Schalter muss abseits der Zentrifuge angebracht sein, vorzugsweise außerhalb des Raumes, in dem sich die Zentrifuge befindet, oder neben dem Ausgang dieses Raumes.
- Die Transportsicherung am Gehäuseboden entfernen, siehe Hinweisblatt "Transportsicherung".
- Die Zentrifuge an einem geeigneten Platz standsicher aufstellen und nivellieren. Bei der Aufstellung ist der geforderte Sicherheitsbereich gemäß IEC 61010-2-020, von 300 mm um die Zentrifuge herum, einzuhalten.



Während eines Zentrifugationslaufes dürfen sich gemäß IEC 61010-2-020, in einem Sicherheitsbereich von 300 mm um die Zentrifuge herum, keine Personen, Gefahrstoffe und Gegenstände befinden.

- Lüftungsöffnungen dürfen nicht zugestellt werden. Es muss ein Lüftungsabstand von 300 mm um die Lüftungsschlitze oder Lüftungsöffnungen eingehalten werden.
- Prüfen ob die Netzspannung mit der Angabe auf dem Typenschild übereinstimmt.
- Die Zentrifuge mit dem Anschlusskabel an eine genormte Netzsteckdose anschließen. Anschlusswert siehe Kapitel "Technische Daten".
- Den Netzschalter einschalten. Schalterstellung "I". Die zuletzt benutzten Zentrifugierdaten werden angezeigt.
- Den Deckel öffnen.



## 9 Deckel öffnen und schließen

### 9.1 Deckel öffnen



Der Deckel lässt sich nur öffnen, wenn die Zentrifuge eingeschaltet ist und der Rotor stillsteht. Sollte dies nicht möglich sein, siehe Kapitel "Notentriegelung".

- Die Griffleiste am Deckel nach oben schwenken. In der Rotationsanzeige  leuchtet das Symbol "L" (Deckel geöffnet).
- Den Deckel öffnen.

### 9.2 Deckel schließen



Den Deckel nicht zuschlagen.

- Den Deckel auflegen und die Griffleiste am Deckel nach unten schwenken. In der Rotationsanzeige  leuchtet das Symbol "—" (Deckel geschlossen).

## 10 Ein- und Ausbau des Rotors

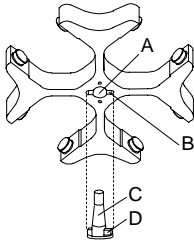

- Die Motorwelle (C) und die Bohrung des Rotors (A) reinigen und anschließend die Motorwelle leicht einfetten. Schmutzpartikel zwischen der Motorwelle und dem Rotor verhindern einen einwandfreien Sitz des Rotors und verursachen einen unruhigen Lauf.
- Den Rotor vertikal auf die Motorwelle aufsetzen. Der Mitnehmer der Motorwelle (D) muss sich in der Nut des Rotors (B) befinden. Auf dem Rotor ist die Ausrichtung der Nut gekennzeichnet.
- Die Spannmutter des Rotors mit dem mitgelieferten Schlüssel durch Drehen im Uhrzeigersinn anziehen.
- Den Rotor auf festen Sitz prüfen.
- Lösen des Rotors: Die Spannmutter durch Drehen entgegen dem Uhrzeigersinn lösen und bis zum Abhebe-Druckpunkt drehen. Nach Überwindung des Abhebe-Druckpunkts löst sich der Rotor vom Konus der Motorwelle. Die Spannmutter drehen, bis sich der Rotor von der Motorwelle abheben lässt.

## 11 Beladen des Rotors



Standard-Zentrifugiergefäße aus Glas sind belastbar bis RZB 4000 (DIN 58970 Teil 2).

- Den Rotor auf festen Sitz prüfen.
- Bei Ausschwingrotoren müssen alle Plätze des Rotors mit **gleichen** Gehängen besetzt sein. Bestimmte Gehänge sind mit der Nummer des Rotorplatzes gekennzeichnet. Diese Gehänge dürfen nur in den entsprechenden Platz des Rotors eingesetzt werden.
- Die Rotoren und Gehänge dürfen nur symmetrisch beladen werden. Zugelassene Kombinationen siehe Kapitel "Anhang/Appendix, Rotoren und Zubehör/Rotors and accessories". Bei Winkelrotoren müssen alle möglichen Plätze des Rotors beladen werden, siehe Kapitel "Anhang/Appendix, Rotoren und Zubehör/Rotors and accessories".
- Auf bestimmten Gehängen ist das Gewicht der maximalen Beladung und das maximale Gewicht des komplett bestückten Gehänges angegeben. Diese Gewichte dürfen nicht überschritten werden. Die Gewichtsangabe der maximalen Beladung umfasst das Gesamtgewicht von Reduzierung, Gestell, Zentrifugiergefäß und Inhalt.
- Bei Behältern mit Gummieinlagen muss sich unter den Zentrifugiergefäßen immer die gleiche Anzahl von Gummieinlagen befinden.
- Die Zentrifugiergefäße immer außerhalb der Zentrifuge befüllen.
- Es darf beim Füllen und beim Ausschwingen der Gehänge keine Flüssigkeit in den Schleuderraum gelangen.
- Die vom Hersteller angegebene maximale Füllmenge der Zentrifugiergefäße darf nicht überschritten werden.
- Um die Gewichtsunterschiede innerhalb der Zentrifugiergefäße möglichst gering zu halten, ist auf eine gleichmäßige Füllhöhe in den Gefäßen zu achten.

## 12 Bedien- und Anzeigeelemente

Siehe Abbildung auf Seite 2.

Fig. 2: Anzeige- und Bedienfeld

### 12.1 Symbole des Bedienfeldes



Rotationsanzeige. Die Rotationsanzeige leuchtet rotierend gegen den Uhrzeigersinn auf, solange sich der Rotor dreht.

Bei Stillstand des Rotors wird in der Rotationsanzeige durch Symbole der Zustand des Deckels angezeigt:

Symbol  : Deckel geöffnet

Symbol  : Deckel geschlossen

Bedienfehler und auftretende Störungen werden im Display angezeigt (siehe Kapitel "Störungen").



### 12.2 Tasten und Einstellmöglichkeiten

RPM/RCF x 100



- Drehzahl

Einstellbar ist ein Zahlenwert von 500 RPM bis zur maximalen Drehzahl des Rotors. Maximale Drehzahl des Rotors siehe Kapitel "Anhang/Appendix, Rotoren und Zubehör/Rotors and accessories". Einstellbar in 100er Schritten (RPM = angezeigter Wert x 100).

Bei Gedrückthalten der Taste  oder  ändert sich der Wert mit zunehmender Geschwindigkeit.

- Die Bremsstufe und den Zentrifugerradius anzeigen.

t





- Laufzeit

- Einstellbar von 1 - 99 Minuten, in 1 Minuten-Schritten

- Dauerlauf "--"

- Zentrifugerradius. Eingabe in Zentimeter. Einstellbar von 5 - 16 Zentimeter, in 1 Zentimeter-Schritten. Zentrifugerradius siehe Kapitel "Anhang/Appendix, Rotoren und Zubehör/Rotors and accessories".

- Bremsstufen 0 oder 1. Stufe 1 = kurze Auslaufzeit, Stufe 0 = lange Auslaufzeit.

Bei Gedrückthalten der Taste  oder  ändert sich der Wert mit zunehmender Geschwindigkeit.

START

- Zentrifugationslauf starten.

STOP

- Zentrifugationslauf beenden.

Der Rotor läuft mit vorgewählter Bremsstufe aus.

- Die Bremsstufe und den Zentrifugerradius speichern.

RCF

- Anzeige der relativen Zentrifugalbeschleunigung (RCF).

Die Anzeige der relativen Zentrifugalbeschleunigung (RCF) erfolgt, solange die Taste  gedrückt gehalten wird.



IMPULS

- Kurzzeitzentrifugation.

Der Zentrifugationslauf erfolgt, solange die Taste  gedrückt gehalten wird.



- Die Bremsstufe und den Zentrifugerradius anzeigen.

### 13 Bremsstufe einstellen

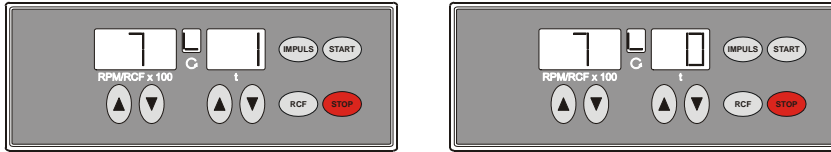
- Den Netzschalter ausschalten.
- Die Taste  unterhalb der Drehzahl-Anzeige und die Taste **[IMPULS]** gleichzeitig gedrückt halten.
- Den Netzschalter einschalten und die Tasten wieder loslassen.
- Die Taste  unterhalb der Drehzahl-Anzeige gegebenenfalls so oft drücken, bis folgende Anzeige erscheint:





In der Drehzahl-Anzeige wird die werksseitig eingestellte Maschinenversion (z.B. 7) und in der Zeit-Anzeige die eingestellte Bremsstufe angezeigt.

- Mit den Tasten   unterhalb der Zeit-Anzeige die gewünschte Bremsstufe einstellen. Stufe 1 = kurze Auslaufzeit, Stufe 0 = lange Auslaufzeit. Auslaufzeiten siehe Kapitel "Anhang/Appendix, Rotoren und Zubehör/Rotors and accessories".
- Die Taste **[STOP]** drücken um die Einstellung zu speichern.



### 14 Zentrifugerradius einstellen

 Der Zentrifugerradius muss in Zentimeter eingegeben werden.

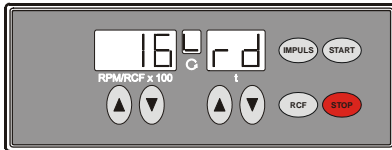
- Den Netzschalter ausschalten.
- Die Taste  unterhalb der Drehzahl-Anzeige und die Taste **[IMPULS]** gleichzeitig gedrückt halten.
- Den Netzschalter einschalten und die Tasten wieder loslassen.
- Die Taste  unterhalb der Drehzahl-Anzeige so oft drücken, bis folgende Anzeige erscheint:









In der Drehzahl-Anzeige wird der eingestellte Zentrifugerradius angezeigt.

- Mit den Tasten   unterhalb der Zeit-Anzeige den gewünschten Zentrifugerradius einstellen. Zentrifugerradius siehe Kapitel "Anhang/Appendix, Rotoren und Zubehör/Rotors and accessories".
- Die Taste **[STOP]** drücken um die Einstellung zu speichern.

### 15 Zentrifugation

 Während eines Zentrifugationslaufes dürfen sich gemäß IEC 61010-2-020, in einem Sicherheitsbereich von 300 mm um die Zentrifuge herum, keine Personen, Gefahrstoffe und Gegenstände befinden.

 Wird der zulässige Gewichtsunterschied innerhalb der Beladung des Rotors überschritten, schaltet der Antrieb während des Anlaufs ab, und Fehler **-3-** wird angezeigt (siehe Kapitel "Störungen"). Ein Zentrifugationslauf kann jederzeit durch Drücken der Taste **[STOP]** abgebrochen werden. Die Zeit und die Drehzahl können während des Zentrifugationslaufes, mit den Tasten  , geändert werden. Bei Gedrückthalten der Taste  oder  ändert sich der Wert mit zunehmender Geschwindigkeit. Nach einem Zentrifugationslauf blinkt die Anzeige bis der Deckel geöffnet, oder eine Taste gedrückt wird. Blinkt in der Rotationsanzeige  abwechselnd das Symbol **"\_"** (Deckel geschlossen) und **"L"** (Deckel geöffnet), so ist eine weitere Bedienung der Zentrifuge erst nach einmaligem Öffnen des Deckels möglich. Wird **rot xx** angezeigt, so hat kein Zentrifugationslauf stattgefunden, weil zuvor der Rotor gewechselt wurde, siehe Kapitel "Rotor-Erkennung".

- Den Netzschalter einschalten (Schalterstellung "I").
- Den Rotor beladen und den Zentrifugendeckel schließen.

### 15.1 Zentrifugation mit Zeitvorwahl

- Mit den Tasten ▲▼ unterhalb der Drehzahl-Anzeige die gewünschte Drehzahl einstellen.
- Mit den Tasten ▲▼ unterhalb der Zeit-Anzeige die gewünschte Zeit einstellen.
- Die Taste **START** drücken. Die Rotationsanzeige  erfolgt solange sich der Rotor dreht.



Die Zeit wird in Minuten angezeigt. Die letzte Minute wird in Sekunden heruntergezählt.  
Wird die Zeit in Minuten angezeigt, blinkt neben der Zahl ein Punkt.

- Nach Ablauf der Zeit oder bei Abbruch des Zentrifugationslaufes durch Drücken der Taste **STOP**, erfolgt der Auslauf des Rotors mit der eingestellten Bremsstufe.

Während des Zentrifugationslaufes werden die Drehzahl des Rotors oder der daraus resultierende RCF-Wert, und die verbleibende Zeit angezeigt.

### 15.2 Dauerlauf

- Mit den Tasten ▲▼ unterhalb der Drehzahl-Anzeige die gewünschte Drehzahl einstellen.
- Mit der Taste ▼ unterhalb der Zeit-Anzeige die Zeit auf Null stellen. Es wird "--" wird angezeigt.
- Die Taste **START** drücken. Die Rotationsanzeige  erfolgt solange sich der Rotor dreht. Die Zeitzählung beginnt bei 0.



Die erste Minute wird in Sekunden hochgezählt, danach wird die Zeit in Minuten angezeigt.  
Wird die Zeit in Minuten angezeigt, blinkt neben der Zahl ein Punkt.

- Die Taste **STOP** drücken um den Zentrifugationslauf zu beenden. Der Auslauf des Rotors erfolgt mit der eingestellten Bremsstufe.

Während des Zentrifugationslaufes werden die Drehzahl des Rotors oder der daraus resultierende RCF-Wert, und die gelaufene Zeit angezeigt.

### 15.3 Kurzzeit zentrifugation

- Mit den Tasten ▲▼ unterhalb der Drehzahl-Anzeige die gewünschte Drehzahl einstellen.
- Die Taste **IMPULS** gedrückt halten. Die Rotationsanzeige  erfolgt solange sich der Rotor dreht. Die Zeitzählung beginnt bei 0.



Die erste Minute wird in Sekunden hochgezählt, danach wird die Zeit in Minuten angezeigt.  
Wird die Zeit in Minuten angezeigt, blinkt neben der Zahl ein Punkt.

- Die Taste **IMPULS** wieder loslassen um den Zentrifugationslauf zu beenden. Der Auslauf des Rotors erfolgt mit der eingestellten Bremsstufe.

Während des Zentrifugationslaufes werden die Drehzahl des Rotors und die gelaufene Zeit angezeigt.

### 15.4 Anzeige der relativen Zentrifugalbeschleunigung (RCF)

Während des Zentrifugationslaufes kann die relative Zentrifugalbeschleunigung (RCF) angezeigt werden.



Wird mit der relativen Zentrifugalbeschleunigung (RCF) gearbeitet, ist die Eingabe des Zentrifugerradius notwendig.

- Während des Zentrifugationslaufes die Taste **RCF** gedrückt halten.  
Die relative Zentrifugalbeschleunigung (RCF) erscheint in der Drehzahl-Anzeige (RCF = angezeigter Wert x 100).
- Die Taste **RCF** wieder loslassen. Es wird wieder die Drehzahl angezeigt.

## 16 Relative Zentrifugalbeschleunigung (RCF)

Die relative Zentrifugalbeschleunigung (RCF) wird als Vielfaches der Erdbeschleunigung (g) angegeben. Sie ist ein einheitsfreier Zahlenwert und dient zum Vergleich der Trenn- und Sedimentationsleistung.

Die Berechnung erfolgt nach der Formel:

$$\text{RCF} = \left( \frac{\text{RPM}}{1000} \right)^2 \times r \times 1,118 \quad \Rightarrow \quad \text{RPM} = \sqrt{\frac{\text{RCF}}{r \times 1,118}} \times 1000$$

RCF = Relative Zentrifugalbeschleunigung

RPM = Drehzahl

r = Zentrifugerradius in mm = Abstand von der Mitte der Drehachse bis zum Zentrifugiergefäßboden.  
Zentrifugerradius siehe Kapitel "Anhang/Appendix, Rotoren und Zubehör/Rotors and accessories".



Die relative Zentrifugalbeschleunigung (RCF) ist abhängig von der Drehzahl und dem Zentrifugerradius.

## 17 Zentrifugation von Stoffen mit höherer Dichte

Die Rotoren sind so konstruiert, dass sie bei angegebener Nenndrehzahl Stoffe mit einer durchschnittlichen homogenen Dichte von max. 1,2 kg/dm<sup>3</sup> zentrifugieren können. Stoffe mit einer höheren Dichte müssen mit reduzierter Drehzahl zentrifugiert werden.

Die erlaubte Drehzahl lässt sich nach folgender Formel berechnen:

$$\text{Reduzierte Drehzahl (n}_{\text{red}}) = \sqrt{\frac{1,2}{\text{höhere Dichte}}} \times \text{Nenndrehzahl}$$

z.B.: RPM 4000, Dichte 1,6 kg/dm<sup>3</sup>

$$n_{\text{red}} = \sqrt{\frac{1,2}{1,6}} \times 4000 = 3464 \text{ RPM}$$

Bei eventuellen Unklarheiten ist Auskunft beim Hersteller einzuholen.

## 18 Rotor-Erkennung

Nach jedem Start eines Zentrifugationslaufes wird der eingesetzte Rotor erkannt.

Nach einem Rotorwechsel schaltet der Antrieb ab und der Rotorcode (rot xx) des Rotors wird angezeigt.

- Die Taste **START** drücken. Die zuletzt benutzten Zentrifugierdaten werden angezeigt.



Eine weitere Bedienung der Zentrifuge ist erst nach einmaligem Öffnen des Deckels möglich.  
Wenn nach einem Rotorwechsel die maximale Drehzahl des Rotors kleiner als die eingestellte Drehzahl ist, wird die Drehzahl auf die maximale Drehzahl des Rotors begrenzt.

## 19 Notentriegelung

Bei einem Stromausfall kann der Deckel nicht geöffnet werden. Es muss eine Notentriegelung von Hand durchgeführt werden.



Zur Notentriegelung die Zentrifuge vom Netz trennen.  
Den Deckel nur bei Stillstand des Rotors öffnen.  
Zur Notentriegelung darf nur der, mitgelieferte Entriegelungsstift aus Kunststoff verwendet werden.

Siehe Abbildung auf Seite 2.

- Den Netzschalter ausschalten (Schalterstellung "0").
- Durch das Fenster im Deckel schauen, um sich zu vergewissern, dass der Rotor stillsteht.
- Den Entriegelungsstift (siehe Lieferumfang) waagrecht in die Bohrung einführen (Fig. 1, A). Den Entriegelungsstift so weit hineinschieben, bis sich beim nach unten Drücken des Stiftes die Griffleiste nach oben schwenken lässt.
- Den Deckel öffnen.

## 20 Pflege und Wartung



Vor der Reinigung den Netzstecker ziehen.

Bevor ein anderes als das vom Hersteller empfohlene Reinigungs- oder Dekontaminationsverfahren angewandt wird, hat sich der Benutzer beim Hersteller zu vergewissern, dass das vorgesehene Verfahren das Gerät nicht schädigt.

- Es sind Reinigungs- oder Desinfektionsmittel zu verwenden, die im pH-Bereich 5 - 8 liegen. Alkalische Reinigungsmittel mit einem pH-Wert > 8 sind zu vermeiden.
- Um Korrosionserscheinungen durch Reinigungs- oder Desinfektionsmittel zu vermeiden sind die speziellen Anwendungshinweise vom Hersteller des Reinigungs- oder Desinfektionsmittels unbedingt zu beachten.

### 20.1 Zentrifuge

- Das Gehäuse der Zentrifuge und den Schleuderraum regelmäßig säubern und bei Bedarf mit Seife oder einem milden Reinigungsmittel und einem feuchten Tuch reinigen. Dies dient zum einen der Hygiene und es verhindert Korrosion durch anhaftende Verunreinigungen.
- Bei Bildung von Kondenswasser den Schleuderraum, durch Auswischen mit einem saugfähigen Tuch, trocknen.
- Gelangt infektiöses Material in den Schleuderraum, so ist dieser umgehend zu desinfizieren. Zur Flächen-Desinfektion empfehlen wir Bacillol® Plus von der Firma Bode Chemie Hamburg oder Biocidal ZF™ von der Firma WAK-Chemie Medical GmbH Steinbach.
- Die Gummidichtung des Schleuderraums nach jeder Reinigung leicht einfetten.

### 20.2 Rotoren und Zubehör

- Um einer Korrosion und Materialveränderungen vorzubeugen müssen die Rotoren und die Zubehörteile regelmäßig mit Seife oder einem milden Reinigungsmittel und einem feuchten Tuch gereinigt werden. Die Reinigung wird mindestens einmal wöchentlich, noch besser nach jedem Gebrauch empfohlen.
- Sind die Rotoren oder die Zubehörteile durch pathogenes oder radioaktives Material verunreinigt, so muss eine geeignete Reinigung durchgeführt werden. Zur Desinfektion empfehlen wir Helipur® H plus N von der Firma B. Braun Melsungen. Zum Entfernen von radioaktivem Material empfehlen wir decon neutracon® von der Firma Decon Laboratories Limited.
- Die Rotoren und Zubehörteile müssen unmittelbar nach der Reinigung getrocknet werden.
- Winkelrotoren, Behälter und Gehänge aus Aluminium sind nach dem Trocknen mit säurefreiem Fett z.B. Vaseline leicht einzufetten.
- Bei aerosoldichten Rotoren und Bio-Sicherheitssystemen (siehe Kapitel "Anhang/Appendix, Rotoren und Zubehör/Rotors and accessories") sind die Dichtungsringe regelmäßig (wöchentlich) zu prüfen und zu reinigen. Bei Anzeichen von Rissbildung, Versprödung oder Abnutzung ist der Dichtungsring sofort auszutauschen. Um ein Verdrehen des Dichtungsringes während dem Öffnen und Schließen des Deckels zu vermeiden, muss der Dichtungsring mit säurefreiem Fett z.B. Vaseline leicht eingefettet werden.
- Um Korrosion infolge Feuchtigkeit zwischen Rotor und Motorwelle zu verhindern, sollte der Rotor mindestens einmal im Monat ausgebaut, gereinigt und die Motorwelle leicht gefettet werden.
- Die Rotoren und die Zubehörteile sind monatlich auf Korrosionsschäden zu überprüfen.



Rotoren und Zubehör dürfen bei Anzeichen von Verschleiß oder Korrosion nicht mehr verwendet werden.

- Den Rotor wöchentlich auf festen Sitz prüfen.

#### 20.2.1 Tragzapfen

Bei Ausschwingrotoren müssen die Tragzapfen regelmäßig gefettet werden (Hettich-Schmierfett Nr. 4051), um ein gleichmäßiges Ausschwingen der Gehänge zu gewährleisten.

#### 20.2.2 Rotoren und Zubehör mit begrenzter Verwendungsdauer

Die Verwendung von bestimmten Rotoren, Gehängen und Zubehörteilen ist zeitlich begrenzt.

Diese sind mit dem Ablaufdatum gekennzeichnet, z.B.: "einsetzbar bis Ende: / usable until end of: IV. Quartal 2011".



Die Rotoren, Gehänge und Zubehörteile dürfen aus Sicherheitsgründen nicht mehr verwendet werden, wenn das darauf gekennzeichnete Ablaufdatum erreicht ist.

### 20.3 Autoklavieren

Ausschwingrotoren, Winkelrotoren aus Aluminium, Gehänge aus Metall, Deckel mit Bioabdichtung sowie Gestelle und Reduzierungen können bei 121°C / 250°F (20 min) autoklaviert werden.

Im Zweifelsfall muss beim Hersteller nachgefragt werden.



Die Deckel der Rotoren und Behälter müssen vor dem Autoklavieren abgenommen werden.

Das Autoklavieren beschleunigt den Alterungsprozess von Kunststoffen. Außerdem kann es bei Kunststoffen Farbveränderungen verursachen.

Wir empfehlen nach dem Autoklavieren die Dichtungsringe von aerosoldichten Rotoren und Bio-Sicherheitssystemen auszutauschen.

### 20.4 Zentrifugiergefäße

- Bei Undichtigkeit oder nach dem Bruch von Zentrifugiergefäßen, sind zerbrochene Gefäßteile, Glassplitter und ausgelaufenes Zentrifugiergut vollständig zu entfernen.
- Die Gummieinlagen sowie die Kunststoff-Hülsen der Rotoren sind nach einem Glasbruch zu ersetzen.



Verbleibende Glassplitter verursachen weiteren Glasbruch !

- Handelt es sich um infektiöses Material so ist umgehend eine Desinfektion durchzuführen.

## 21 Störungen

Lässt sich der Fehler laut Störungstabelle nicht beheben, so ist der Kundendienst zu benachrichtigen.

Bitte den Zentrifugentyp und die Werknummer angeben. Beide Werte sind auf dem Typenschild der Zentrifuge ersichtlich.

-  Einen NETZ-RESET durchführen:
- Den Netzschalter ausschalten (Schalterstellung "0").
  - Mindestens 10 Sekunden lang warten und anschließend den Netzschalter wieder einschalten (Schalterstellung "I").

Störung	Anzeige	Fehlerursache	Beseitigung
keine Anzeige	---	Keine Spannung. Netzeingangssicherungen defekt.	<ul style="list-style-type: none"> <li>- Versorgungsspannung überprüfen.</li> <li>- Netzeingangssicherungen überprüfen, siehe Kapitel "Netzeingangssicherungen wechseln".</li> <li>- Netzschalter EIN.</li> </ul>
Tachofehler	- 1 -	Ausfall der Drehzahlimpulse.	<ul style="list-style-type: none"> <li>- Der Deckel lässt sich aus Sicherheitsgründen erst nach ca. 120 Sekunden öffnen.</li> <li>- Nach Ablauf dieser Zeit einen "NETZ-RESET" durchführen.</li> </ul>
NETZ-RESET	- 2 -	Netzunterbrechung während des Zentrifugationslaufes. (Der Zentrifugationslauf wurde nicht beendet.)	<ul style="list-style-type: none"> <li>- Nach Stillstand Deckel öffnen und Taste <b>START</b> betätigen.</li> <li>- Bei Bedarf den Zentrifugationslauf wiederholen.</li> </ul>
Unwucht	- 3 -	Der Rotor ist ungleichmäßig beladen.	<ul style="list-style-type: none"> <li>- Deckel nach Rotor-Stillstand öffnen.</li> <li>- Die Beladung des Rotors überprüfen, siehe Kapitel "Beladen des Rotors".</li> <li>- Den Zentrifugationslauf wiederholen.</li> </ul>
Kommunikation	- 4 -	Fehler im Steuerteil oder Leistungsteil.	<ul style="list-style-type: none"> <li>- Nach Stillstand des Rotors einen NETZ-RESET durchführen.</li> </ul>
Überlast	- 5 -	Motor oder Motoransteuerung defekt.	<ul style="list-style-type: none"> <li>- Nach Stillstand des Rotors einen NETZ-RESET durchführen.</li> </ul>
Überspannung Unterspannung	- 6 - - 8 -	Netzspannung außerhalb der Toleranzen (siehe Technische Daten).	<ul style="list-style-type: none"> <li>- Nach Stillstand des Rotors einen NETZ-RESET durchführen.</li> <li>- Netzspannung kontrollieren.</li> </ul>
Überdrehzahl	- 7 -	Fehler im Leistungsteil.	<ul style="list-style-type: none"> <li>- Nach Stillstand des Rotors einen NETZ-RESET durchführen.</li> </ul>
Übertemperatur	- 9 -	Übertemperaturschalter im Motor hat ausgelöst.	<ul style="list-style-type: none"> <li>- Nach Rotor-Stillstand Deckel durch Notentriegelung öffnen (siehe Kapitel Notentriegelung).</li> <li>- Motor abkühlen lassen.</li> </ul>
Version Error	In der Zeit-Anzeige wird eine Zahl angezeigt.	Falsche Maschinenversion eingestellt, Steuerteil springt in das Einstell-Menü.	<ul style="list-style-type: none"> <li>- Mit den Tasten   unterhalb der Zeit-Anzeige die Zahl 4 einstellen.</li> <li>- Die Taste <b>STOP</b> drücken um die Einstellung zu speichern.</li> <li>- Einen NETZ-RESET durchführen.</li> </ul>
Controller-Watchdog	- C -	Fehler im Steuerteil.	<ul style="list-style-type: none"> <li>- Nach Stillstand des Rotors einen NETZ-RESET durchführen.</li> </ul>
Deckelfehler	- d -	Fehler Deckelverriegelung.	<ul style="list-style-type: none"> <li>- Nach Stillstand des Rotors einen NETZ-RESET durchführen.</li> </ul>
Kurzschluss	- E -	Kurzschluss in Steuerteil / Leistungsteil.	<ul style="list-style-type: none"> <li>- Nach Stillstand des Rotors einen NETZ-RESET durchführen.</li> </ul>
Kein Rotorcode	- F -	Keine Rotorerkennung beim Start. Kein Rotor eingesetzt oder defekter Tacho.	<ul style="list-style-type: none"> <li>- Nach Stillstand des Rotors einen NETZ-RESET durchführen.</li> </ul>
Neuer Rotor erkannt	rot...	siehe Kapitel Rotorerkennung	<ul style="list-style-type: none"> <li>- Die Taste <b>START</b> drücken.</li> </ul>



## 22 Netzeingangssicherungen wechseln



Den Netzschalter ausschalten und die Zentrifuge vom Netz trennen!

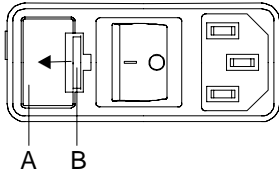

Der Sicherungshalter (A) mit den Netzeingangssicherungen befindet sich neben dem Netzschalter.

- Das Anschlusskabel aus dem Gerätestecker ziehen.
- Den Schnappverschluss (B) gegen den Sicherungshalter (A) drücken und diesen herausziehen.
- Defekte Netzeingangssicherungen austauschen.



Nur Sicherungen mit dem, für den Typ, festgelegten Nennwert verwenden, siehe nachfolgende Tabelle.

- Den Sicherungshalter wieder hineinschieben bis der Schnappverschluss einrastet.
- Die Zentrifuge wieder ans Netz anschließen.

Modell	Typ	Sicherung	Best.-Nr.
ROTOFIX 32 A	1206	T 3,15 AH/250V	E997
ROTOFIX 32 A	1206-01	T 5 AH/250V	E914

## 23 Reparaturannahme von Zentrifugen

Wird die Zentrifuge zur Reparatur an den Hersteller zurückgesandt, so muss diese, zum Schutz von Personen, Umwelt und Material, vor dem Versand dekontaminiert und gereinigt werden.

Eine Annahme von kontaminierten Zentrifugen behalten wir uns vor.

Anfallende Kosten für Reinigungs- und Desinfektionsmaßnahmen werden dem Kunden in Rechnung gestellt.

Wir bitten dafür um Ihr Verständnis.

## 24 Entsorgung

Bei der Entsorgung des Geräts sind die jeweiligen gesetzlichen Vorschriften zu beachten.

Gemäß der Richtlinie 2002/96/EG (WEEE) dürfen alle nach dem 13.08.2005 gelieferten Geräte nicht mehr mit dem Hausmüll entsorgt werden. Das Gerät gehört zur Gruppe 8 (Medizinische Geräte) und ist in den Business-to-Business-Bereich eingeordnet.



Mit dem Symbol des durchgestrichenen Abfalleimers wird darauf hingewiesen, dass das Gerät nicht mit dem Hausmüll entsorgt werden darf.

Die Entsorgungsvorschriften der einzelnen EU-Länder können unterschiedlich sein. Im Bedarfsfall wenden Sie sich bitte an Ihren Lieferanten.

**Contents**

1	Use according to specification .....	19
2	Residual risks .....	19
3	Technical specifications .....	19
4	Notes on safety .....	20
5	Symbol meanings .....	21
6	Delivery checklist .....	21
7	Unpacking the centrifuge .....	21
8	Initial operation .....	21
9	Opening and closing the lid .....	22
9.1	Opening the lid .....	22
9.2	Closing the lid .....	22
10	Installation and removal of the rotor .....	22
11	Loading the rotor .....	22
12	Control and display elements .....	23
12.1	Symbols on the control panel .....	23
12.2	Keys and setting options .....	23
13	Setting the brake step .....	24
14	Setting the centrifuging radius .....	24
15	Centrifugation .....	24
15.1	Centrifugation with preselected time .....	25
15.2	Continuous operation .....	25
15.3	Short-time centrifugation .....	25
15.4	Display of the relative centrifugal force (RCF) .....	25
16	Relative centrifugal force (RCF) .....	25
17	Centrifugation of materials with higher density .....	26
18	Rotor Identification .....	26
19	Emergency release .....	26
20	Maintenance and servicing .....	26
20.1	Centrifuge .....	26
20.2	Rotors and Attachments .....	27
20.2.1	Trunnions .....	27
20.2.2	Rotors and accessories with limited term of use .....	27
20.3	Autoclaving .....	27
20.4	Centrifuge containers .....	27
21	Faults .....	28
22	Change mains input fuse .....	29
23	Acceptance of the centrifuges for repair .....	29
24	Disposal .....	29
25	Anhang / Appendix .....	56
25.1	Rotoren und Zubehör / Rotors and accessories .....	56

### 1 Use according to specification

The machine presented here is a medical product (laboratory centrifuge) according to the IVD guideline 98/79/EG. The centrifuge is used to separate substances or substance mixtures with a density of max. 1.2 kg/dm<sup>3</sup>. This also includes substances and substance mixtures of human origin. The centrifuge is only intended to be used for this purpose. A different use or application over and above this is deemed not in accordance with the specifications. The company Andreas Hettich GmbH & Co. KG undertakes no liability for damages resulting therefrom.

Belonging to the application according to specification is also the observance of all references contained in the Instruction Manual and compliance with the inspection and maintenance works.

### 2 Residual risks

The machine is constructed according to the state of the art and the recognized technical safety regulations. Improper use and handling can result in dangers to life and limb of the user or third parties and impairments to the machine or to other material assets. The machine is only to be used for the specified applications and only in an impeccable technical safety condition.

Disturbances that can interfere with the safety are to be immediately rectified.

### 3 Technical specifications

Manufacturer	Andreas Hettich GmbH & Co. KG D-78532 Tuttlingen	
Model	ROTOFIX 32 A	
Type	1206	1206-01
Mains voltage (± 10%)	208 – 240 V 1~	100 – 127 V 1~
Mains frequency	50 – 60 Hz	50 – 60 Hz
Connected load	300 VA	300 VA
Current consumption	1.4 A	3.0 A
Max. capacity	4 x 100 ml / 32 x 15 ml	
Allowed density	1.2 kg/dm <sup>3</sup>	
Speed (RPM)	6000	
Force (RCF)	4186	
Kinetic energy	3160 Nm	
Obligatory inspection (BGR 261)	no	
Ambient conditions (EN 61010-1)	<ul style="list-style-type: none"> <li>– Set-up site Indoors only</li> <li>– Altitude Up to 2000 m above sea level</li> <li>– Ambient temperature 2°C to 40°C</li> <li>– Humidity Maximum relative humidity 80% for temperatures up to 31°C, linearly decreasing to 50% relative humidity at 40°C.</li> <li>– Excess-voltage category (IEC 60364-4-443) II</li> <li>– Pollution degree 2</li> </ul>	
Device protection class	I	
Not suitable for use in explosion-endangered areas.		
EMC	<ul style="list-style-type: none"> <li>– Emitted interference (suppression of radio interference) EN 55011, Group 1, Class B EN 61000-3-2 EN 61000-3-3</li> <li>– Interference immunity EN 61000-6-2</li> </ul>	
		FCC Class B
		----
Noise level (dependent on rotor)	≤ 57 dB(A)	
Dimensions	<ul style="list-style-type: none"> <li>– Width 366 mm</li> <li>– Depth 430 mm</li> <li>– Height 257 mm</li> </ul>	
Weight	23 kg	

#### 4 Notes on safety



**No claim under guarantee will be considered by the manufacturer unless the above instructions have been adhered to.**

- **Before the initial operation of your centrifuge you should read and pay attention to the operating instructions.  
Only personnel that has read and understood the operating instructions are allowed to operate the device.**
- Along with the operating instructions and the legal regulations on accident prevention, you should also follow the recognised professional regulations for working in a safe and professional manner. These operating instructions should be read in conjunction with any other instructions concerning accident prevention and environmental protection based on the national regulations of the country where the device is to be used.
- This centrifuge is a state-of-the-art piece of equipment which is extremely safe to operate.
  - However, it can lead to danger for users or others if used by untrained staff, in an inappropriate way or for a purpose other than that it was designed for.
- The centrifuge should be installed on a good, stable base.
- Before using the centrifuge absolutely check the rotor for firm placement.
- When the centrifuge is running, according to IEC 61010-2-020, no persons, dangerous substances or objects may be within the safety margin of 300 mm around the centrifuge.
- The centrifuge must not be moved or knocked during operation.
- In case of fault or emergency release, never touch the rotor before it has stopped turning.
- To avoid damage due to condensate, when changing from a cold to a warm room the centrifuge must either heat up for at least 3 hours in the warm room before being connected to the mains, or run hot for 30 minutes in the cold room.
- Only the rotors and accessories approved by the manufacturer for this device may be used (see chapter "Anhang/Appendix, Rotoren und Zubehör/Rotors and accessories").
- The centrifuge rotor may only be loaded in accordance with the chapter "Loading the rotor".
- When centrifuging with maxim revolutions per minute the density of the materials or the material mixtures may not exceed 1.2 kg/dm<sup>3</sup>.
- The centrifuge may only be operated when the balance is within the bounds of acceptability.
- The centrifuge may not be operated in explosion-endangered areas.
- The centrifuge must not be used with:
  - inflammable or explosive materials
  - materials that react with one another producing a lot of energy.
- If users have to centrifuge hazardous materials or compounds contaminated with toxic, radioactive or pathogenic micro-organisms, they must take appropriate measures.
 

For hazardous substances centrifuge containers with special screw caps must strictly be used. In addition to the screw cap centrifuge containers, for materials in hazard category 3 and 4 a biosafety system must be used (see the World Health Organisation's "Laboratory Biosafety Manual").

Under a biosafety system small drips and aerosols are prevented from escaping by a bioseal (packing ring) located between the hanger and the lid.

If the hanger of a biosafety system is used without the lid, the packing ring must be removed from the hanger in order to prevent the packing ring from being damaged during the centrifugation run. Damaged packing rings must not be used to seal the biosafety system.

Without the use of a biosafety system the centrifuge is not microbiologically sealed in the sense of the EN 61010-2-020 standard.

For further details of available biosafety systems see chapter "Anhang/Appendix, Rotoren und Zubehör/Rotors and accessories". If in doubt, you should obtain relevant information from the manufacturer.
- The centrifuge must not be operated with highly corrosive substances which could impair the mechanical integrity of rotors, hangers and accessories.
- Rotors, suspensions and accessories that possess traces of corrosion or mechanical damage or if their term of use has expired may not be used any longer.
- Repairs must only be carried out by personnel authorised to do so by the manufacturer.
- Only original spare parts and original accessories licensed by the Andreas Hettich GmbH & Co. KG company are allowed to be utilised.
- The following safety regulations apply:
  - IEC 61010-1 and IEC 61010-2-020 as well as their national deviations.
- The safe operation and reliability of the centrifuge can only be guaranteed if:
  - the centrifuge is operated in accordance with the operating instructions,
  - the electrical installation on the site where the centrifuge is installed conforms to the demands of IEC stipulations,
  - prescribed tests to BGV A1, BGR 261 are carried out by an expert.

## 5 Symbol meanings



Symbol on the machine:

Attention, general hazard area.

Before using the centrifuge implicitly read the operating instructions and pay attention to the safety relevant references!



Symbol in the operating instructions:

Attention, general hazard area.

This symbol refers to safety relevant warnings and indicates possibly dangerous situations.

The non-adherence to these warnings can lead to material damage and injury to personal.



Symbol in the operating instructions:

This symbol refers to important circumstances.



Symbol on the machine and in the operating instructions:

Symbol for the separate collection of electric and electronic devices according to the guideline 2002/96/EG (WEEE). The device belongs to Group 8 (medical devices).

Applies in the countries of the European Union, as well as in Norway and Switzerland.

## 6 Delivery checklist

The following items and accessories are delivered with the centrifuge:

- |   |                                      |
|---|--------------------------------------|
| 1 | Connecting cable                     |
| 2 | Fuses                                |
| 1 | Lubricating grease for trunnions     |
| 1 | Hex. pin driver                      |
| 1 | Release pin                          |
| 1 | Notes on moving the equipment safely |
| 1 | Operating instructions               |

The rotor(s) and associated accessories are included in the delivery in the quantity.

## 7 Unpacking the centrifuge

- Lift the carton upward and remove the padding.



Do not lift by the handle rail.

Observe the weight of the centrifuge, refer to chapter "Technical specifications".

Lift the centrifuge on both sides with an appropriate number of helpers and place it on the laboratory table.

## 8 Initial operation

- According to the laboratory instrument standards IEC 61010-2-020 an emergency switch to separate power supply in the event of a failure must be installed in the building electrical system. This switch has to be placed remote from the centrifuge, preferred outside of the room in which the centrifuge is installed or near by the exit of this room.
- Remove the transportation safety device from the bottom of the housing, see sheet "Transportation safety device".
- Position the centrifuge in a stable and level manner in a suitable place. During set-up, the required safety margin of 300 mm around the centrifuge is to be kept according to IEC 61010-2-020.



When the centrifuge is running, according to IEC 61010-2-020, no persons, dangerous substances or objects may be within the safety margin of 300 mm around the centrifuge.

- Do not place any object in front of the ventiduct. Keep a ventilation area of 300 mm around the ventiduct.
- Check whether the mains voltage tallies with the statement on the type plate.
- Connect the centrifuge with the connection cable to a standard mains socket. For connection ratings refer to Chapter "Technical specifications".
- Turn on the mains switch. Switch position "I". The last used centrifuge data will be displayed.
- Open the lid.

## 9 Opening and closing the lid

### 9.1 Opening the lid



The lid can only be opened when the centrifuge is switched on and the rotor is at rest. If it cannot be opened under these circumstances, see the section on "Emergency release".

- Swing handle rail on the lid upwards. The symbol "L" (lid open) illuminates in the rotation indicator Ⓞ.
- Open the lid.

### 9.2 Closing the lid



Do not bang the lid shut.

- Place the lid and swing handle rail on the lid downward. The symbol "—" (lid closed) illuminates in the rotation indicator Ⓞ.

## 10 Installation and removal of the rotor

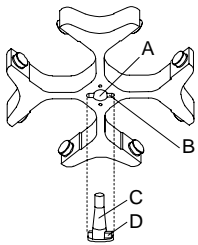

- Clean the motor shaft (C) and the rotor drilling (A), and lightly grease the motor shaft afterwards. Dirt particles between the motor shaft and the rotor hinder a perfect seating of the rotor and cause an irregular operation.
- Place the rotor vertically on the motor shaft. The motor shaft dog (D) has to fit in the rotor slot (B). The alignment of the groove is labelled on the rotor.
- Tighten the rotor tension nut with the supplied wrench by turning in a clockwise direction.
- Check the rotor for firm seating.
- Loosening the rotor: Loosen the tension nut by turning in a counter clockwise direction, and turning until the working point for lifting. After passing the working point for lifting the rotor is loosened from the motor shaft cone. Turn the tension nut until the rotor is able to be lifted from the motor shaft.

## 11 Loading the rotor



Standard centrifuge containers of glass will not stand RCF values exceeding 4000 (DIN 58970, pg. 2).

- Check the rotor for firm seating.
- With swing-out rotors all rotor positions must be lined with **identical** hangers. Certain hangers are marked with the number of the rotor position. These hangers may only be used in the respective rotor position.
- The rotors and hangers may only be loaded symmetrically. For authorised combinations see Chapter "Anhang/Appendix, Rotoren und Zubehör/Rotors and accessories".  
In the case of angle rotors all possible rotor positions must be loaded, see chapter "Anhang/Appendix, Rotoren und Zubehör/Rotors and accessories".
- On certain suspensions, the weight of the maximum load and the maximum weight of the suspension when it is fully equipped is displayed. This weight may not be exceeded. The weight specified for the maximum loading includes the total weight of adapter, frame, centrifuging container and content.
- In containers with rubber inserts, the same number of rubber inserts must always be among the centrifuge containers.
- Always fill the centrifuge containers outside of the centrifuge.
- No liquid should be allowed to enter the centrifugal chamber during filling and swinging out of the hangers.
- The maximum filling quantity for the centrifuge containers specified by the manufacturer must not be exceeded.
- In order to maintain the weight differences within the centrifuge container as marginal as possible, a consistent fill level in the containers is to be heeded.

## 12 Control and display elements

See figure on page 2.

Fig. 2: Display and control panel

### 12.1 Symbols on the control panel



Rotation indicator. The rotation indicator lights up and rotates anticlockwise while the rotor is turning.

When the rotor is stationary, the status of the lid is displayed by symbols in the rotation indicator:

Symbol  : Lid open

Symbol  : Lid closed

Operator errors and occurring faults are indicated on the display (see Chapter "Faults").



### 12.2 Keys and setting options

RPM/RCF x 100



- Speed

A numeric value of 500 RPM up to the maximum rotor speed can be set. For maximum rotor speed, see chapter "Anhang/Appendix, Rotoren und Zubehör/Rotors and accessories". Preset in steps of 100 (RPM = displayed value x 100).

If the key  or  is kept pressed, the value changes with increasing speed.

- Display the brake step and the centrifuging radius.

t





- Running time

- Preset from 1 - 99 minutes, in 1 minute steps

- Continuous operation "--"

- Centrifuging radius. Input in centimeters. Preset from 5 - 16 centimeters, in 1 centimeter steps. For centrifuging radius, see chapter "Anhang/Appendix, Rotoren und Zubehör/Rotors and accessories".
- Braking steps 0 or 1. Step 1 = short run-down time, Step 0 = long run-down time.

If the key  or  is kept pressed, the value changes with increasing speed.



- Start centrifugation run.



- End centrifugation run.  
The rotor runs down with the preselected brake step.
- Save the brake step and the centrifuging radius.





- Display of the relative centrifugal force (RCF).  
The display of the relative centrifugal force (RCF) appears while the key  is kept pressed.





- Short-time centrifugation.  
The centrifugation run occurs while the key  is kept pressed.
- Display the brake step and the centrifuging radius.

### 13 Setting the brake step

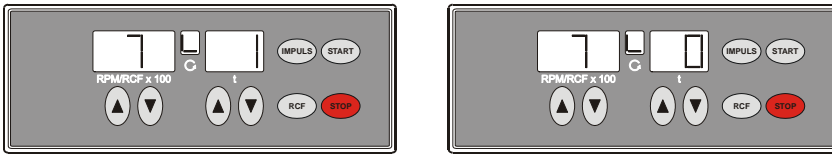
- Switch off the mains switch.
- Keep the key  beneath the speed indicator and the key **[IMPULS]** pressed simultaneously.
- Switch on the mains switch and release the keys again.
- Press the key  beneath the speed indicator until the following display appears:





The machine version set in the factory (e.g. 7) is displayed in the speed indicator and the set brake step is displayed in the time indicator.

- Set the desired brake step with the keys   beneath the time indicator.  
Step 1 = short run-down time, Step 0 = long run-down time.  
For run-down times, see chapter "Anhang/Appendix, Rotoren und Zubehör/Rotors and accessories".
- Press the key **[STOP]** to save the setting.



### 14 Setting the centrifuging radius

 The centrifuging radius must be entered in centimeters.

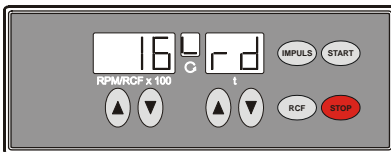
- Switch off the mains switch.
- Keep the key  beneath the speed indicator and the key **[IMPULS]** pressed simultaneously.
- Switch on the mains switch and release the keys again.
- Press the key  beneath the speed indicator until the following display appears:









The set centrifuging radius is displayed in the speed indicator.

- Set the desired centrifuging radius with the keys   beneath the time indicator.  
For centrifuging radius, see chapter "Anhang/Appendix, Rotoren und Zubehör/Rotors and accessories".
- Press the key **[STOP]** to save the setting.

### 15 Centrifugation

 When the centrifuge is running, according to IEC 61010-2-020, no persons, dangerous substances or objects may be within the safety margin of 300 mm around the centrifuge.

 If the permissible weight difference is exceeded within the rotor loading, the drive switches off during the run-up time, and error **-3-** is displayed (see chapter "Faults").  
The centrifugation run can be interrupted at any time by pressing the key **[STOP]**.  
The time and speed can be changed during the centrifugation run, with the keys  .  
If the key  or  is kept pressed, the value changes with increasing speed.  
After a centrifugation run, the display flashes until the cover is opened or a key is pressed.  
If the symbol "—" (lid closed) and "L" (lid open) flashes alternately in the rotation indicator , operation of the centrifuge can only be continued after opening the lid.  
If **rot xx** is displayed, no centrifugation run has taken place because the rotor has been changed, see chapter "Rotor Identification".

- Switch on the mains switch (switch position "I").
- Load the rotor and close the centrifuge cover.



### 15.1 Centrifugation with preselected time

- Set the desired speed with the keys  $\blacktriangle$   $\blacktriangledown$  beneath the speed indicator.
- Set the desired time with the keys  $\blacktriangle$   $\blacktriangledown$  beneath the time indicator.
- Press the key **[START]**. The rotation indicator  $\odot$  appears while the rotor is turning.



The time is displayed in minutes. The last minute is counted down in seconds.  
When the time is displayed in minutes, a point flashes next to the number.

- After expiry of the time or if the centrifugation run is interrupted by pressing the key **[STOP]**, the rotor runs down with the set brake step.

During the centrifugation run, the rotor speed or the resulting RCF value and the remaining time are displayed.

### 15.2 Continuous operation

- Set the desired speed with the keys  $\blacktriangle$   $\blacktriangledown$  beneath the speed indicator.
- Set the time to zero with the key  $\blacktriangledown$  beneath the time indicator. "--" is displayed.
- Press the key **[START]**. The rotation indicator  $\odot$  appears while the rotor is turning. The time count starts from 0.



The first minute is counted up in seconds, and then the time is displayed in minutes.  
When the time is displayed in minutes, a point flashes next to the number.

- Press the key **[STOP]** to end the centrifugation run. The rotor runs down with the set brake step.

During the centrifugation run, the rotor speed or the resulting RCF value and the expired time are displayed.

### 15.3 Short-time centrifugation

- Set the desired speed with the keys  $\blacktriangle$   $\blacktriangledown$  beneath the speed indicator.
- Keep the key **[IMPULS]** pressed. The rotation indicator  $\odot$  appears while the rotor is turning. The time count starts from 0.



The first minute is counted up in seconds, and then the time is displayed in minutes.  
When the time is displayed in minutes, a point flashes next to the number.

- Release the key **[IMPULS]** again to end the centrifugation run. The rotor runs down with the set brake step.

During the centrifugation run, the rotor speed and the expired time are displayed.

### 15.4 Display of the relative centrifugal force (RCF)

The relative centrifugal force (RCF) can be displayed during the centrifugation run.



If the relative centrifugal force (RCF) is used, the centrifuging radius must be entered.

- Keep the key **[RCF]** pressed during the centrifugation run.  
The relative centrifugal force (RCF) appears in the speed indicator (RCF = displayed value x 100).
- Release the key **[RCF]** again. The speed is displayed.

## 16 Relative centrifugal force (RCF)

The relative centrifugal force (RCF) is given as a multiple of the acceleration of gravity (g). It is a unit-free value and serves to compare the separation and sedimentation performance.

These values are calculated using the formula below:

$$\text{RCF} = \left( \frac{\text{RPM}}{1000} \right)^2 \times r \times 1,118 \quad \Rightarrow \quad \text{RPM} = \sqrt{\frac{\text{RCF}}{r \times 1,118}} \times 1000$$

RCF = relative centrifugal force

RPM = rotational speed (revolutions per minute)

r = centrifugal radius in mm = distance from the centre of the turning axis to the bottom of the centrifuge.

For more on the centrifugal radius see the chapter "Anhang/Appendix, Rotoren und Zubehör/Rotors and accessories".



The relative centrifugal force (RCF) stands in relation to the revolutions per minute and the centrifugal radius.

## 17 Centrifugation of materials with higher density

The rotors are designed to centrifuge substances up to a maximum mean homogenous density of 1.2 kg/dm<sup>3</sup> when rotating at the stated speed.

Denser substances must be centrifuged at lower speed.

The permissible speed can be calculated using the following formula:

$$\text{Reduced speed (n}_{\text{red}}) = \sqrt{\frac{1.2}{\text{Greater density}}} \times \text{Rated speed}$$

e.g.: RPM 4000, density 1.6 kg/dm<sup>3</sup>

$$n_{\text{red}} = \sqrt{\frac{1.2}{1.6}} \times 4000 = 3464 \text{ RPM}$$

If in doubt you should obtain clarification from the manufacturer.

## 18 Rotor Identification

After every start of a centrifugation run the rotor utilised is identified.

After a rotor change, the drive switches off and the rotor code (rot xx) is displayed.

- Press the key **START**. The last used centrifuge data will be displayed..



A further operation of the centrifuge is only possible after a single opening of the lid.

If, following a rotor change, the maximum speed of the rotor is less than the set speed, the speed is limited to the maximum speed of the rotor.

## 19 Emergency release

The lid cannot be opened during power failure. An emergency release has to be executed by hand.



For emergency release disconnect the centrifuge from the mains.

Open the lid only during rotor standstill.

Only the plastic release pin provided may be used for emergency release.

See figure on page 2.

- Switch off the mains switch (switch position "0").
- Look through the window in the lid to be sure that the rotor has come to a standstill.
- Insert the release pin (see scope of supply) horizontally into the hole (Fig. 1, A). Push the unlocking pin in until the handle can be lifted when the pin is pressed down.
- Open the lid.

## 20 Maintenance and servicing



Pull the mains plug before cleaning.

Before any other cleaning or decontamination process other than that recommended by the manufacturer is applied, the user has to check with the manufacturer that the planned process does not damage the device.

- Cleaning agents and disinfectants which lie in the pH range 5 – 8 are to be utilised. Alkaline cleaning agents with a pH value > 8 are to be avoided.
- In order to prevent appearances of corrosion through cleaning agents or disinfectants, the application guide from the manufacturer of the cleaning agent or disinfectant are absolutely to be heeded.

### 20.1 Centrifuge

- Clean the centrifuge housing and the centrifuging chamber regularly, using soap or a mild detergent and a damp cloth if required. For one thing, this services purposes of hygiene, and it also prevents corrosion through adhering impurities.
- In the event of condensation water formation, dry the centrifugal chamber by wiping out with an absorbent cloth.
- If infectious materials penetrates into the centrifugal chamber this is to be disinfected immediately. For surface disinfection we recommend Bacillol® manufactured by Bode Chemie in Hamburg or Biocidal ZF™ from the company WAK-Chemie Medical GmbH in Steinbach.
- Lightly grease the rubber seal of the centrifugal chamber after every cleaning.

## 20.2 Rotors and Attachments

- In order to prevent corrosion and material changes, rotors and accessories must be cleaned regularly with soap or a mild detergent and a damp cloth. Cleaning is recommended at least once a week, even better after every usage.
- If the rotor or accessory parts are contaminated by pathogenic or radioactive material, a suitable cleaning has to be executed. For disinfection we recommend Helipur® H plus N from the company B. Braun Melsungen. For the removal of radioactive material we recommend decon neutracon® from the company Decon Laboratories Limited.
- The rotors and accessory parts must be dried immediately after cleaning.
- Angle rotors, container and hanger made of aluminium are to be lightly greased after drying using acid-free grease, e.g. vaseline.
- With aerosol-sealed rotors and bio safety systems (see Chapter "Anhang/Appendix, Rotoren und Zubehör/Rotors and accessories") the sealing rings are to be checked and cleaned regularly (weekly). The sealing ring is to be replaced immediately upon indication of crack formation, embrittlement or abrasive wear. To prevent the sealing ring from twisting when the lid is opened and closed, the sealing ring must be lightly greased with acid-free grease, such as Vaseline.
- In order to prevent corrosion as a result of moisture between the rotor and the motor shaft, the rotor should be disassembled and cleaned at least once a month, and the motor shaft should be lightly greased.
- The rotors and accessory parts are to be checked on a monthly basis for corrosion damage.



Rotors and attachments may no longer be utilised upon indication of wear and tear or corrosion.

- Check the firm seating of the rotor on a weekly basis.

### 20.2.1 Trunnions

With swing-out rotors the trunnions must be regularly lubricated (Hettich Lubricating Grease No. 4051) in order to ensure consistent swinging out of the hangers.

### 20.2.2 Rotors and accessories with limited term of use

The use of specific rotors, suspensions and accessories is time limited.

They are marked with an expiry date, e.g. "einsetzbar bis Ende: / usable until end of: IV. Quartal 2011" (applicable until the end of: IVth quarter 2011).



The rotors, suspensions and accessories may not be used for longer periods for safety reasons once the marked expiry date has been reached.

## 20.3 Autoclaving

Swing-out rotors, angle rotors made of aluminium, suspension made of metal, lids with biodegradable seals as well as stands and reductions can be autoclaved at 121° C / 250°F (20 mins).

Otherwise you must ask the manufacturer.



The lids of the rotors and containers must be removed prior to autoclaving. Autoclaving accelerates the ageing process of plastics. In addition, autoclaving may discolour plastics. After autoclaving, we recommend that the sealing rings of the aerosol-tight and bio-safety systems be exchanged.

## 20.4 Centrifuge containers

- With leakiness or after the breakage of centrifuging containers broken container parts and leaked centrifugation material are to be completely removed.
- The rubber inserts as well as the plastic sleeves of the rotors are to be replaced after a glass breakage.



Remaining glass splitters cause further glass breakage!

- If this concerns infectious material, a disinfection process is to be executed immediately.

## 21 Faults

If the fault cannot be eliminated with the help of the fault table, please inform Customer Service.

Please state the type of centrifuge and the factory serial number. Both values are visible on the centrifuge type plate.



Perform a MAINS RESET:

- Switch off the mains switch (switch position "0").
- Wait at least 10 seconds and then switch on the mains switch again (switch position "1").

Fault	Display	Cause of fault	Remedy
No display	---	No voltage Mains input fuses defective.	<ul style="list-style-type: none"> <li>- Check distribution voltage.</li> <li>- Check mains power input fuse, refer to Chapter "Change mains input fuse".</li> <li>- Mains switch ON.</li> </ul>
Tacho error	- 1 -	Failure of speed impulses during operation.	<ul style="list-style-type: none"> <li>- Due to safety reasons the lid can only be opened after approx. 120 seconds.</li> <li>- After this time has expired perform a MAINS-RESET.</li> </ul>
System reset	- 2 -	Power failure during the centrifugation run. (The centrifugation run was not finished.)	<ul style="list-style-type: none"> <li>- When stationary, open lid and press <b>[START]</b> key.</li> <li>- Repeat the centrifugation run if necessary.</li> </ul>
Balance error	- 3 -	The rotor is unevenly loaded.	<ul style="list-style-type: none"> <li>- Open lid when rotor is stationary.</li> <li>- Check the loading of the rotor, see chapter "Loading the rotor".</li> <li>- Repeat the centrifugation run.</li> </ul>
Communication	- 4 -	Fault in control unit or power unit.	<ul style="list-style-type: none"> <li>- Perform a MAINS RESET when the rotor has been stationary.</li> </ul>
Overload	- 5 -	Motor or motor control defective.	<ul style="list-style-type: none"> <li>- Perform a MAINS RESET when the rotor has been stationary.</li> </ul>
Overvoltage Undervoltage	- 6 - - 8 -	Supply voltage outside tolerance (see Technical Data).	<ul style="list-style-type: none"> <li>- Perform a MAINS RESET when the rotor has been stationary.</li> <li>- Check supply voltage.</li> </ul>
Overspeed	- 7 -	Fault in the power unit.	<ul style="list-style-type: none"> <li>- Perform a MAINS RESET when the rotor has been stationary</li> </ul>
Excess temperature	- 9 -	Excess temperature switch in motor has triggered.	<ul style="list-style-type: none"> <li>- When rotor is stationary, open lid using emergency unlocking (see Emergency Unlocking chapter).</li> <li>- Allow motor to cool down.</li> </ul>
Version error	A number is displayed in the time indicator.	Incorrect machine version set, control unit jumps into Setting menu.	<ul style="list-style-type: none"> <li>- Set the number 4 using the <b>[▲]</b> <b>[▼]</b> keys underneath the time indicator.</li> <li>- Press the key <b>[STOP]</b> to save the setting.</li> <li>- Perform a MAINS RESET.</li> </ul>
Controller watchdog	- C -	Fault in control unit.	<ul style="list-style-type: none"> <li>- Perform a MAINS RESET when the rotor has been stationary.</li> </ul>
Lid error	- d -	Error in lid locking or lid closure.	<ul style="list-style-type: none"> <li>- Perform a MAINS RESET when the rotor has been stationary.</li> </ul>
Short circuit	- E -	Short circuit in control unit / power unit.	<ul style="list-style-type: none"> <li>- Perform a MAINS RESET when the rotor has been stationary.</li> </ul>
No rotor code	- F -	No rotor recognition at start. No rotor fitted or defective tacho.	<ul style="list-style-type: none"> <li>- Perform a MAINS RESET when the rotor has been stationary.</li> </ul>
New rotor identified	rot...	see section rotor identification.	<ul style="list-style-type: none"> <li>- Press the key <b>[START]</b>.</li> </ul>

## 22 Change mains input fuse



Switch off the mains switch and separate the centrifuge from the mains!

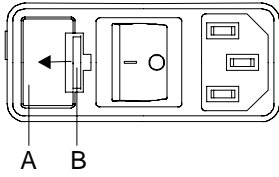

The fuse holder (A) with the mains input fuses is located next to the mains switch.

- Remove the connecting cable from the machine plug socket.
- Press the snap-fit (B) against the fuse holder (A) and remove.
- Exchange defective mains input fuses.



Only use fuses with the rating defined for the type. See the following table.

- Reinsert the fuse holder until the snap-fit clicks shut.
- Reconnect the centrifuge to the mains supply.

Model	Type	Fuse	Order no.
ROTOFIX 32 A	1206	T 3.15 AH/250V	E997
ROTOFIX 32 A	1206-01	T 5 AH/250V	E914

## 23 Acceptance of the centrifuges for repair

If the centrifuge is returned to the manufacturer for repair, it must be decontaminated and cleaned to protect persons, environment and material.

We reserve the right to accept contaminated centrifuges.

Costs incurred for cleaning and disinfection are to be charged to the customer.

We ask for your understanding in this matter.

## 24 Disposal

When you are disposing of the device, the respective statutory rules must be observed.

Pursuant to guideline 2002/96/EC (WEEE), all devices supplied after August 13, 2005 may not be disposed as part of domestic waste. The device belongs to group 8 (medical devices) and is categorized in the business-to-business field.



The icon of the crossed-out trash can shows that the device may not be disposed as part of domestic waste.

The waste disposal guidelines of the individual EC countries might vary. If necessary, contact your supplier.

**Table des matières**

1	Usage conforme .....	31
2	Risques résiduels .....	31
3	Données techniques .....	31
4	Consignes de sécurité .....	32
5	Signification des symboles .....	33
6	Composition de la livraison .....	33
7	Déballer la centrifugeuse .....	33
8	Mise en service.....	33
9	Ouvrir et fermer le couvercle .....	34
9.1	Ouvrir le couvercle.....	34
9.2	Fermer le couvercle.....	34
10	Montage et démontage du rotor .....	34
11	Chargement du rotor .....	34
12	Organes de commande et indicateurs.....	35
12.1	Symboles du tableau de commande.....	35
12.2	Touches et possibilités de réglage.....	35
13	Régler le niveau de freinage .....	36
14	Régler le rayon de centrifugation .....	36
15	Centrifugation.....	37
15.1	Centrifugation après présélection du temps.....	37
15.2	Fonctionnement continu.....	37
15.3	Centrifugation de courte durée.....	37
15.4	Affichage de l'accélération centrifuge relative (RCF) .....	38
16	Accélération centrifuge relative (RCF).....	38
17	Centrifugation de substances à haute densité .....	38
18	Identification de rotor.....	38
19	Déverrouillage d'urgence .....	39
20	Entretien et maintenance .....	39
20.1	Centrifugeuse.....	39
20.2	Rotors et accessoires .....	39
20.2.1	Goupilles de fixation .....	40
20.2.2	Rotors et accessoires ayant une durée d'utilisation limitée.....	40
20.3	Autoclavage .....	40
20.4	Réservoirs de centrifugation .....	40
21	Défauts.....	41
22	Changer les fusibles d'entrée de secteur .....	42
23	Réparation des centrifugeuses.....	42
24	Élimination des déchets .....	42
25	Anhang / Appendix.....	56
25.1	Rotoren und Zubehör / Rotors and accessories.....	56

## 1 Usage conforme

La présente machine correspond à un produit de médecine (centrifugeuse de laboratoire) au sens de la directive IVD 98/79/EG. La centrifugeuse sert à séparer les substances ou les substances mélangées ayant une densité supérieure à 1,2 kg/dm<sup>3</sup> au max. Cela concerne également les substances et les substances mélangées d'origine humaine. La centrifugeuse est uniquement destinée à cette utilisation. Tout usage autre ou dépassant ce contexte est considéré comme non-conforme. La société Andreas Hettich GmbH & Co. KG décline toute responsabilités pour les dégâts causés par un usage non-conforme.

L'usage conforme comprend également le respect des instructions du mode d'emploi et l'exécution des travaux d'inspection et de maintenance.

## 2 Risques résiduels

La machine est construite selon l'état de la technique et les règles de sécurité technique reconnues. Une utilisation et un maniement incorrect peuvent entraîner des risques de blessure et de décès pour l'utilisateur ou les tiers ou bien provoquer des dommages sur la machine ou les autres biens matériels. La machine doit uniquement être utilisée dans le cadre de son usage conforme et dans un état de sécurité technique irréprochable.

Il convient de dépanner immédiatement tout dérangement susceptible d'affecter la sécurité.

## 3 Données techniques

Fabricant	Andreas Hettich GmbH & Co. KG D-78532 Tuttlingen	
Modèle	ROTOFIX 32 A	
Type	1206	1206-01
Tension du réseau ( $\pm 10\%$ )	208 – 240 V 1~	100 – 127 V 1~
Fréquence du réseau	50 – 60 Hz	50 – 60 Hz
Charge de connexion	300 VA	300 VA
Consommation de courant	1.4 A	3.0 A
Capacité max.	4 x 100 ml / 32 x 15 ml	
Densité admise	1.2 kg/dm <sup>3</sup>	
Vitesse de rotation (RPM)	6000	
Accélération (RCF)	4186	
Energie cinétique	3160 Nm	
Obligation de contrôle (BGR 261)	non	
Conditions ambiantes (EN 61010-1)	uniquement dans les intérieurs Jusqu'à 2000 m au dessus du niveau de la mer 2°C à 40°C humidité de l'air max. relative 80% pour températures jusqu'à 31°C, décroissant en linéaire jusqu'à 50% de l'humidité relative pour 40°C.	
– Emplacement		
– Hauteur		
– Température ambiante		
– Humidité de l'air		
– Catégorie de surtension (IEC 60364-4-443)	II	
– Degré d'encrassement	2	
Catégorie de protection de l'appareil	I	
Non approprié pour l'usage dans un environnement exposé aux explosions.		
EMV	FCC Class B	
– Emission de parasites (antiparasitage)	EN 55011, Groupe 1, catégorie B EN 61000-3-2 EN 61000-3-3	
– Résistance aux interférences	EN 61000-6-2	----
Niveau du bruit (en fonction du rotor)	$\leq 57$ dB(A)	
Dimensions		
– Largeur	366 mm	
– Profondeur	430 mm	
– Hauteur	257 mm	
Poids	23 kg	

## 4 Consignes de sécurité



**Le non respect des présentes consignes exclut tout recours à la garantie.**

- **Il importe de lire et de respecter le mode d'emploi avant la mise en service de la centrifugeuse. Seules les personnes ayant lu et compris le mode d'emploi sont autorisées à manipuler l'appareil.**
- Outre le mode d'emploi et les réglementations contraignantes relatives à la prévention des accidents, il importe également de respecter les règles spécifiques et communément admises en matière de sécurité et de travail. Le mode d'emploi doit être complété des dispositions nationales applicables à la prévention des accidents et à la protection de l'environnement.
- La centrifugeuse a été construite conformément à l'état actuel de la technique et son fonctionnement est sûr.
  - Elle peut cependant présenter des dangers pour l'utilisateur ou des tiers si son utilisation n'est pas confiée à un personnel dûment formé, est inadéquate ou non conforme à sa destination.
- Veiller à la stabilité de la centrifugeuse.
- Avant d'utiliser la centrifugeuse, il est indispensable de vérifier la fixation correcte du rotor.
- Durant un processus de centrifugation, aucune personne, matière dangereuse et aucun objet ne doivent se trouver dans une zone de sécurité de 300 mm autour de la centrifugeuse selon IEC 61010-2-020.
- Pendant le fonctionnement, la centrifugeuse ne devra pas être déplacée ou être heurtée.
- En cas de défaillance ou en cas de déverrouillage d'urgence, ne jamais intervenir dans l'appareil lorsque le rotor tourne.
- Afin d'éviter les dommages causés par la condensation en passant d'un local froid à un local chaud, il faut soit réchauffer la centrifugeuse en la laissant pendant au moins 3 heures dans le local chaud avant de la raccorder au secteur, soit la faire fonctionner pendant 30 minutes dans le local froid pour la chauffer.
- Pour cet appareil, vous ne devez utiliser que des rotors et des accessoires homologués par le fabricant (voir chapitre "Anhang/Appendix, Rotoren und Zubehör/Rotors and accessories").
- Le rotor de la centrifugeuse doit uniquement être chargé conformément au chapitre "Chargement du rotor".
- Dans le cas de la centrifugation à la vitesse maximale, la densité des substances et des mélanges de substances ne doit pas excéder  $1,2 \text{ kg/dm}^3$ .
- Il est interdit de procéder à des centrifugations en présence de défauts d'équilibrage.
- La centrifugeuse ne doit pas être exploitée dans un environnement explosif.
- Il est interdit de procéder à des centrifugations :
  - avec des matières inflammables ou explosives,
  - avec des matières susceptibles de réagir chimiquement ou de dégager d'importantes quantités d'énergie.
- En cas de centrifugation de substances dangereuses ou de substances mixtes toxiques, radioactives ou contaminées par des micro-organismes pathogènes, il incombe à l'utilisateur de prendre les mesures ad hoc. Il faut systématiquement utiliser des récipients de centrifugation avec des bouchons spéciaux à vis destinés aux substances dangereuses. Dans le cas des substances des groupes de risques 3 et 4, il faut utiliser un système de sécurité biologique en plus des récipients de centrifugation pouvant être obturés (voir le manuel "Laboratory Biosafety Manual" publié par l'Organisation Mondiale de la Santé).  
 Dans un système de sécurité biologique, un joint biologique (bague d'étanchéité) placé entre les supports et le capot empêchera la fuite de gouttelettes et d'aérosols.  
 Lorsque la suspension d'un système de sécurité biologique est utilisée sans couvercle, il faut enlever la bague d'étanchéité de la suspension pour éviter de l'endommager pendant le cycle de centrifugation. Les bagues endommagées ne doivent plus être utilisées pour assurer l'étanchéité le système de sécurité biologique.  
 En l'absence d'un système de sécurité biologique, une centrifugeuse n'est pas étanche du point de vue microbiologique au sens de la norme EN 61010-2-020.  
 Pour ce qui concerne les systèmes à sécurité biologique, voir le chapitre "Anhang/Appendix, Rotoren und Zubehör/Rotors and accessories". Dans le doute vous pouvez obtenir les informations auprès du fabricant.
- Il est interdit de centrifuger des matières fortement corrosives pouvant réduire la résistance mécanique des rotors, des supports et des accessoires.
- Les rotors, balanciers et accessoires qui présentent d'importantes traces de corrosion ou des défauts mécaniques ou dont la durée d'utilisation a expiré ne doivent plus être utilisés.
- Les réparations ne peuvent être effectuées que par une personne autorisée à cet effet par le fabricant.
- Utiliser uniquement les pièces de rechange originales et les accessoires d'origine homologués par les Etablissements Andreas Hettich GmbH & Co. KG.
- Les dispositions de sécurité suivantes font foi :  
IEC 61010-1 et IEC 61010-2-020 ainsi que les dérogations nationales.
- La sécurité et la fiabilité de la centrifugeuse seront uniquement garanties si :
  - la centrifugeuse est utilisée conformément aux instructions du mode d'emploi,
  - l'installation électrique du site de la centrifugeuse est conforme aux prescriptions IEC,
  - les contrôles prescrits selon BGV A1, BGR 261 sont effectués par un personnel spécialisé averti.



## 5 Signification des symboles



Symbole sur la machine:

Attention, zone de danger général.

Avant l'utilisation de la centrifugeuse, il est indispensable de lire le mode d'emploi et de respecter les consignes de sécurité !



Symbole dans le mode d'emploi:

Attention, zone de danger général.

Ce symbole indique des consignes de sécurité et signale des situations pouvant être sources de danger.

Le non-respect de ces instructions peut entraîner des dégâts matériels et personnels.



Symbole dans le mode d'emploi:

Ce symbole signale des informations importantes.



Symbole sur la machine et dans le mode d'emploi:

Symbole pour la collecte séparée des appareils électriques et électroniques, conformément à la directive 2002/96(EG (WEEE). L'appareil fait partie du groupe 8 (appareils de médecine).

Utilisation dans les pays de l'Union Européenne ainsi qu'en Norvège et en Suisse.

## 6 Composition de la livraison

Les accessoires suivants sont fournis avec la centrifugeuse:

- 1 Câble de connexion
- 2 Fusible
- 1 Graisse pour tourillon porteur
- 1 Clé mâle coudée
- 1 Tige de déverrouillage
- 1 Fiche de consignes pour le transport
- 1 Mode d'emploi

Le(s) rotor(s) et accessoires correspondant sont livrés selon les spécifications de la commande.

## 7 Déballez la centrifugeuse

- Soulever le carton et retirer le matériau d'amortissement.



Ne pas utiliser la poignée du couvercle pour soulever.

Tenir compte du poids de la centrifugeuse, voir au chapitre "Données techniques".

Avec un nombre suffisant d'aides, soulever la centrifugeuse sur les deux faces et la déposer sur la table de laboratoire.

## 8 Mise en service

- Aux termes de la norme EN sur les laboratoires IEC 61010-2-020, l'installation locale doit être équipée d'un interrupteur d'arrêt d'urgence pour sectionner l'alimentation du secteur en cas de défaut. Cet interrupteur doit être éloigné de la centrifugeuse, de préférence hors de la pièce dans laquelle est la centrifugeuse ou près de la porte.
- Retirer du fond du carter les dispositifs de sécurité pour le transport, voir pour cela la fiche de données "Dispositifs de sécurité pour le transport".
- Placer la centrifugeuse sur un emplacement approprié de manière à ce qu'elle soit stable et mettre de niveau. Lors de la mise en place, il faut respecter la zone de sécurité exigée de 300mm autour de la centrifugeuse selon IEC 61010-2-020.



Durant un processus de centrifugation, aucune personne, matière dangereuse et aucun objet ne doivent se trouver dans une zone de sécurité de 300 mm autour de la centrifugeuse selon IEC 61010-2-020.

- Ne pas placer d'objet devant la grille de ventilation. Ménager un espace de ventilation de 300 mm autour de la grille.
- Vérifier que la tension de secteur est identique à la mention de la plaque signalétique.
- Raccorder la centrifugeuse à une prise de secteur normalisée au moyen du câble de connexion. Puissance connectée voir chapitre "Données techniques".
- Activer l'interrupteur de secteur. Amener l'interrupteur en position "I". Les dernières données de centrifuge utilisées s'affichent.
- Ouvrir le capot.

## 9 Ouvrir et fermer le couvercle

### 9.1 Ouvrir le couvercle



Le capot ne peut être ouvert que lorsque la centrifugeuse est sous tension et que le rotor est à l'arrêt. Dans les autres cas, voir le chapitre, "Déverrouillage d'urgence".

- Faire pivoter la baguette de la poignée du couvercle vers le haut. Le symbole "L" (couvercle ouvert) est allumé dans l'affichage de la rotation .
- Ouvrir le capot.

### 9.2 Fermer le couvercle



Ne pas laisser tomber le couvercle pour le fermer.

- Poser le couvercle dessus et faire pivoter la baguette de la poignée du couvercle vers le bas. Le symbole "—" (couvercle fermé) est allumé dans l'affichage de la rotation .

## 10 Montage et démontage du rotor

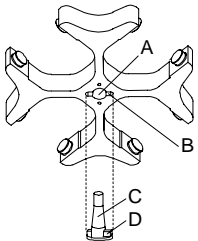

- Nettoyer l'arbre d'entraînement (C) et l'alésage du rotor (A) et enduire ensuite l'arbre d'entraînement d'une pellicule de graisse. Les particules d'impuretés entre l'arbre d'entraînement et le rotor réduisent la stabilité d'assise du rotor et provoquent un fonctionnement irrégulier.
- Enfiler le rotor à la verticale sur l'arbre d'entraînement. Le taquet de l'arbre d'entraînement (D) doit être logé dans la rainure du rotor (B). L'orientation de la rainure est indiquée sur le rotor.
- Serrer l'écrou de fixation du rotor avec la clé de la livraison en tournant dans le sens horloger.
- Vérifier la stabilité d'assise du rotor.
- Démontage du rotor : Desserrer l'écrou de fixation par rotation dans le sens anti-horloger jusqu'à ce que le rotor puisse être détaché par pression. En exerçant une légère pression, détacher le rotor du cône de l'arbre d'entraînement. Dévisser l'écrou de fixation jusqu'à ce que le rotor soit détaché de l'arbre d'entraînement.

## 11 Chargement du rotor



Des récipients standard de centrifugation en verre sont résistants jusqu'à un ACR de 4000 (DIN 58970, partie 2).

- Vérifier la stabilité d'assise du rotor.
- Les rotors doivent uniquement être chargés de manière symétrique. Pour les combinaisons possibles, voir le Chapitre "Anhang/Appendix, Rotoren und Zubehör/Rotors and accessories".
- Les récipients de centrifugation doivent toujours être remplis hors de la centrifugeuse.
- La quantité maximale de remplissage indiquée par le fabricant pour les récipients de centrifugation ne doit pas être dépassée.
- La hauteur de remplissage des récipients sera autant que possible égale pour maintenir les différences de poids entre les récipients de centrifugation aussi réduites que possible.
- Le poids du volume de remplissage autorisé est indiqué sur chaque rotor. Il est interdit de dépasser cette tare.

## 12 Organes de commande et indicateurs

Voir illustration sur la page 2.

Fig. 2: Console des indicateurs et organes de commande

### 12.1 Symboles du tableau de commande



Affichage de la rotation. L'affichage de la rotation s'allume en tournant dans le sens inverse des aiguilles d'une montre, tant que le rotor tourne.

L'état du couvercle est indiqué grâce aux symboles dans l'affichage de la rotation pendant l'immobilisation du rotor :

Symbole  : couvercle ouvert



Symbole  : couvercle fermé

Les erreurs de commande et les dérangements qui surviennent sont indiqués à l'écran (voir au chapitre "Défauts").

### 12.2 Touches et possibilités de réglage

#### RPM/RCF x 100 • Vitesse de rotation





- La valeur numérique pouvant être réglée va de 500 RPM à la vitesse de rotation maximale du rotor. Pour la vitesse de rotation maximale du rotor, voir au chapitre "Annexe/Appendix, Rotors et accessoires/Rotors and accessories". Réglage par pas de 100 (RPM = valeur indiquée x 100). Lorsque vous maintenez enfoncée la touche  ou , la valeur change de plus en plus rapidement.
- Afficher le niveau de freinage et le rayon de centrifugation.

t



- Temps de marche
  - Réglage de 1 à 99 minutes, par pas de 1 minute
  - Fonctionnement continu "--"
- Rayon de centrifugation. Saisie en centimètres. Réglage de 5 à 16 centimètres, par pas de 1 centimètre. Pour le rayon de centrifugation, voir au chapitre "Annexe/Appendix, Rotors et accessoires/Rotors and accessories".
- Niveau de freinage 0 ou 1. Niveau 1 = temps de ralentissement court, niveau 0 = temps de ralentissement long.

Lorsque vous maintenez enfoncée la touche  ou , la valeur change de plus en plus rapidement.



- Démarrer le cycle de centrifugation.



- Terminer le cycle de centrifugation. Le rotor ralentit avec le niveau de freinage présélectionné.
- Sauvegarder le niveau de freinage et le rayon de centrifugation.



- Affichage de l'accélération centrifuge relative (RCF). L'accélération centrifuge relative (RCF) est indiquée tant que la touche  est maintenue enfoncée.



- Centrifugation de courte durée. Le cycle de centrifugation a lieu tant que la touche  est maintenue enfoncée.
- Afficher le niveau de freinage et le rayon de centrifugation.

### 13 Régler le niveau de freinage

- Couper l'interrupteur de secteur.
- Appuyer simultanément sur la touche ▲ située en dessous de l'affichage de la vitesse de rotation et sur la touche (IMPULS).
- Fermer l'interrupteur de secteur et relâcher les touches.
- Appuyer le cas échéant sur la touche ▲ située en dessous de l'affichage de la vitesse de rotation, jusqu'à ce que l'affichage suivant apparaisse :

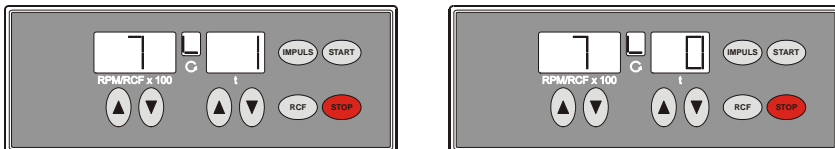

La version de la machine réglée à l'usine est indiquée dans l'affichage de la vitesse de rotation (p.ex. 7) et le niveau de freinage réglé dans l'affichage du temps.

- Régler le niveau de freinage souhaité avec les touches ▲▼ situées en dessous de l'affichage du temps. Niveau 1 = temps de ralentissement court, niveau 0 = temps de ralentissement long. Pour les temps de ralentissement, voir au chapitre "Anhang/Appendix, Rotoren und Zubehör/Rotors and accessories".
- Appuyer sur la touche (STOP) pour sauvegarder le réglage.

### 14 Régler le rayon de centrifugation

 Le rayon de centrifugation doit être saisi en centimètres.

- Couper l'interrupteur de secteur.
- Appuyer simultanément sur la touche ▲ située en dessous de l'affichage de la vitesse de rotation et sur la touche (IMPULS).
- Fermer l'interrupteur de secteur et relâcher les touches.
- Appuyer sur la touche ▲ située en dessous de l'affichage de la vitesse de rotation, jusqu'à ce que l'affichage suivant apparaisse :

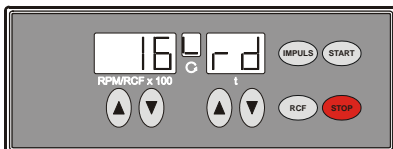

Le rayon de centrifugation est indiqué dans l'affichage de la vitesse de rotation.

- Régler le rayon de centrifugation souhaité avec les touches ▲▼ situées en dessous de l'affichage du temps. Pour le rayon de centrifugation, voir au chapitre "Anhang/Appendix, Rotoren und Zubehör/Rotors and accessories".
- Appuyer sur la touche (STOP) pour sauvegarder le réglage.

## 15 Centrifugation



Durant un processus de centrifugation, aucune personne, matière dangereuse et aucun objet ne doivent se trouver dans une zone de sécurité de 300 mm autour de la centrifugeuse selon IEC 61010-2-020.



Si la différence de poids admissible est dépassée pendant le chargement du rotor, l'entraînement s'arrête pendant le démarrage et l'erreur **-3-** s'affiche (voir au chapitre "Défauts").

Un cycle de centrifugation peut être interrompu à tout moment en appuyant sur la touche **[STOP]**.

Le temps et la vitesse peuvent être modifiés pendant le cycle de centrifugation avec les touches **[▲]** **[▼]**.

Lorsque vous maintenez enfoncée la touche **[▲]** ou **[▼]**, la valeur change de plus en plus rapidement.

L'affichage clignote après un cycle de centrifugation jusqu'à l'ouverture du couvercle ou l'appui d'une touche.

Lorsque le symbole "—" (couvercle fermé) et "L" (couvercle ouvert) clignote à tour de rôle dans l'affichage de la rotation **[C]**, il est alors seulement possible d'exécuter une nouvelle commande de la centrifugeuse après une ouverture du couvercle.

Lorsque **rot xx** s'affiche, c'est qu'aucun cycle de centrifugation n'a eu lieu, car le rotor a été auparavant changé, voir au chapitre "Identification de rotor".

- Fermer l'interrupteur de secteur (position de l'interrupteur "I").
- Charger le rotor et fermer le couvercle de la centrifugeuse.

### 15.1 Centrifugation après présélection du temps

- Régler la vitesse de rotation souhaitée avec les touches **[▲]** **[▼]** situées en dessous de l'affichage de la vitesse de rotation.
- Régler le temps souhaité avec les touches **[▲]** **[▼]** situées en dessous de l'affichage du temps.
- Appuyer sur la touche **[START]**. La rotation **[C]** est indiquée tant que le rotor fonctionne.



Le temps est indiqué en minutes. La dernière minute est décomptée en secondes.  
Lorsque le temps est indiqué en minutes, un point clignote à côté du chiffre.

- Après l'expiration du temps ou l'interruption du cycle de centrifugation en appuyant sur la touche **[STOP]**, le ralentissement du rotor a lieu avec le niveau de freinage réglé.

La vitesse de rotation du rotor ou la valeur RCF en résultant et le temps qui reste s'affichent pendant le cycle de centrifugation.

### 15.2 Fonctionnement continu

- Régler la vitesse de rotation souhaitée avec les touches **[▲]** **[▼]** situées en dessous de l'affichage de la vitesse de rotation.
- Mettre le temps à zéro avec la touche **[▼]** située en dessous de l'affichage du temps. "--" s'affiche.
- Appuyer sur la touche **[START]**. La rotation **[C]** est indiquée tant que le rotor fonctionne. Le chronométrage commence à 0.



La première minute est comptée en secondes, le temps s'affiche ensuite en minutes.  
Lorsque le temps est indiqué en minutes, un point clignote à côté du chiffre.

- Appuyer sur la touche **[STOP]** pour terminer le cycle de centrifugation. Le ralentissement du rotor a lieu avec le niveau de freinage réglé.

La vitesse de rotation du rotor ou la valeur RCF en résultant et le temps écoulé s'affichent pendant le cycle de centrifugation.

### 15.3 Centrifugation de courte durée

- Régler la vitesse de rotation souhaitée avec les touches **[▲]** **[▼]** situées en dessous de l'affichage de la vitesse de rotation.
- Maintenir enfoncée la touche **[IMPULS]**. La rotation **[C]** est indiquée tant que le rotor fonctionne. Le chronométrage commence à 0.



La première minute est comptée en secondes, le temps s'affiche ensuite en minutes.  
Lorsque le temps est indiqué en minutes, un point clignote à côté du chiffre.

- Relâcher la touche **[IMPULS]** pour terminer le cycle de centrifugation. Le ralentissement du rotor a lieu avec le niveau de freinage réglé.

La vitesse de rotation du rotor et le temps écoulé s'affichent pendant le cycle de centrifugation.

## 15.4 Affichage de l'accélération centrifuge relative (RCF)

L'accélération centrifuge relative (RCF) peut être indiquée pendant le cycle de centrifugation.

 Lorsque vous travaillez avec l'accélération centrifuge relative (RCF), il faut saisir le rayon de centrifugation.

- Maintenir enfoncée la touche **[RCF]** pendant le cycle de centrifugation. L'accélération centrifuge relative (RCF) apparaît dans l'affichage de la vitesse de rotation (RCF = valeur indiquée x 100).
- Relâcher la touche **[RCF]**. La vitesse de rotation est à nouveau indiquée.

## 16 Accélération centrifuge relative (RCF)

L'accélération centrifuge relative (RCF) est indiquée en tant que multiple de l'accélération gravitationnelle (g). Il s'agit d'une valeur dépourvue d'unité, qui sert à la comparaison entre la puissance de séparation et de sédimentation.

Le calcul s'effectue à l'aide de la formule suivante:

$$RCF = \left( \frac{RPM}{1000} \right)^2 \times r \times 1,118 \quad \Rightarrow \quad RPM = \sqrt{\frac{RCF}{r \times 1,118}} \times 1000$$

RCF = accélération centrifuge relative

RPM = régime

r = rayon de centrifugation en mm = distance qui sépare le centre de l'axe de rotation du fond de la cuve de centrifugation. Rayon de centrifugation voir chapitre "Anhang/Appendix, Rotoren und Zubehör/Rotors and accessories".

 L'accélération centrifuge relative (RCF) est dépendante du régime et du rayon de centrifugation.

## 17 Centrifugation de substances à haute densité

Les rotors sont conçus pour centrifuger à vitesse de rotation nominale des matières à densité homogène moyenne maximale de 1,2 kg/dm<sup>3</sup>. Les matières à densités plus élevées doivent être centrifugées à vitesse plus lente.

La vitesse de rotation autorisée se calcule de la manière suivante:

$$\text{Vitesse de centrifugation lente (n}_{red}\text{)} = \sqrt{\frac{1,2}{\text{densité supérieure}}} \times \text{Vitesse de rotation nominale}$$

Exemple: RPM 4000, densité 1,6 kg/dm<sup>3</sup>

$$n_{red} = \sqrt{\frac{1,2}{1,6}} \times 4000 = 3464 \text{ RPM}$$

En cas d'incertitude, prendre contact avec le fabricant.

## 18 Identification de rotor

Après démarrage de chaque cycle de centrifugation, la machine exécute une routine d'identification du rotor utilisé. L'entraînement s'arrête après un changement de rotor et le code du rotor (rot xx) s'affiche.

- Appuyer sur la touche **[START]**. Les dernières données de centrifuge utilisées s'affichent.

 Toute commande ultérieure de la centrifuge n'est possible qu'après une ouverture du couvercle. Suite à un changement de rotor, si la vitesse maximale de rotation du rotor est inférieure à la vitesse de rotation paramétrée, la vitesse de rotation est limitée à la vitesse maximale de rotation du rotor.

## 19 Déverrouillage d'urgence

En cas de panne de courant, le couvercle ne peut pas être ouvert. Il est nécessaire d'exécuter un déverrouillage manuel.



Avant d'exécuter le déverrouillage manuel, retirer la fiche de l'alimentation.

Attendre que le rotor est à l'arrêt pour ouvrir le couvercle.

Seule la tige de déverrouillage en plastique fournie peut être utilisée pour un déverrouillage d'urgence.

Voir illustration sur la page 2.

- Couper l'interrupteur de secteur (position de l'interrupteur "0").
- Regarder par la fenêtre située sur le couvercle pour s'assurer que le rotor est immobile.
- Introduire la goupille de déverrouillage horizontalement (voir étendue de la livraison) dans le forage (Fig. 1, A). Enfoncez la tige de déverrouillage jusqu'à ce que vous puissiez faire pivoter la languette de saisie vers le haut lorsque vous poussez la tige vers le bas.
- Ouvrir le capot.

## 20 Entretien et maintenance



Retirer la prise de secteur avant de nettoyer.

Avant d'utiliser une procédure de nettoyage ou de décontamination autre que celle recommandée par le fabricant, l'utilisateur vérifiera auprès du fabricant que la procédure prévue n'endommage pas l'appareil.

- Utiliser des agents de nettoyage et de désinfection de pH entre 5 et 8. Ne pas utiliser les agents de nettoyage alcalins d'un pH > 8.
- Respecter impérativement les consignes spéciales d'utilisation données par le fabricant des agents de nettoyage et de désinfection, afin de prévenir la corrosion par les agents de nettoyage et de désinfection.

### 20.1 Centrifugeuse

- Nettoyer régulièrement le boîtier de la centrifugeuse et le compartiment de centrifugation et les laver en cas de besoin avec du savon ou un détergent doux et un chiffon humide. Ces opérations sont nécessaires pour garantir l'hygiène et pour prévenir la corrosion par la présence durable d'impuretés.
- Sécher le bol avec un chiffon absorbant en cas de dépôt d'eau de condensation dans le bol de la centrifugeuse.
- Le bol de la centrifugeuse doit être nettoyé immédiatement dans le cas où un matériau infectieux a pénétré dans le bol de la centrifugeuse. Pour désinfecter des surfaces, nous recommandons Bacillol® Plus de la société Bode Chemie de Hambourg ou Biocidal ZF™ de la société WAK-Chemie Medical GmbH de Steinbach.
- Enduire d'un film de graisse le joint en caoutchouc du bol de centrifugeuse au terme de chaque nettoyage.

### 20.2 Rotors et accessoires

- Afin de prévenir la corrosion et les modifications des matériaux, il faut laver régulièrement les rotors et les accessoires avec du savon ou un détergent doux et un chiffon humide. Exécuter le nettoyage au moins une fois par semaine, l'idéal étant de nettoyer après chaque utilisation.
- Un nettoyage approprié sera exécuté dans le cas où le rotor et les accessoires ont été contaminés par un matériau pathogène ou radioactif. Nous recommandons de procéder à la désinfection avec Helipur® H plus N de la société B. Braun Melsungen. Pour éliminer les matières radioactives, nous recommandons decon neutracon® de la société Decon Laboratories Limited.
- Sécher les rotors et les accessoires immédiatement après le nettoyage.
- Après séchage, les rotors d'angle, les réservoirs et la suspension en aluminium seront enduits d'une pellicule de graisse sans acide, par exemple la vaseline.
- Vérifier régulièrement les bagues d'étanchéité (une fois par semaine) sur les rotors étanches aux aérosols et les systèmes de sécurité biologiques (voir le chapitre "Anhang/Appendix, Rotoren und Zubehör/Rotors and accessories"). Changer immédiatement la bague d'étanchéité si elle présente des marques de fissuration, de friabilité et d'usure. Pour éviter une déformation de l'anneau d'étanchéité au cours de l'ouverture et de la fermeture du couvercle, l'anneau doit être légèrement graissé avec de la graisse sans acide, par ex. Vaseline.
- Déposer le rotor au moins une fois par mois, nettoyer et enduire l'arbre d'entraînement d'une pellicule de graisse pour prévenir la corrosion par la présence d'humidité entre le rotor et l'arbre d'entraînement.
- Vérifier une fois par mois que les rotors et les accessoires ne sont pas endommagés par la corrosion.



Les rotors et les accessoires usés et endommagés par la corrosion ne doivent plus être utilisés.

- Vérifier chaque semaine la stabilité de fixation du rotor.

### 20.2.1 Goupilles de fixation

Les goupilles de fixation des rotors à amortissement doivent être graissées régulièrement (graisse de lubrification Hettich n° 4051) de manière à assurer le balancement régulier de la suspension.

### 20.2.2 Rotors et accessoires ayant une durée d'utilisation limitée

L'utilisation de certains rotors, balanciers et accessoires est limitée dans le temps.

Ceux-ci sont marqués avec une date d'expiration, par ex. : "einsetzbar bis Ende: / usable until end of: IV. Quartal 2011" (utilisable jusqu'à la fin du 4<sup>e</sup> trimestre 2011).



Les rotors, balanciers et accessoires ne doivent plus être utilisés pour des raisons de sécurité, lorsque la date d'expiration qui est marquée dessus a été atteinte.

### 20.3 Autoclavage

Les rotors à oscillation, les rotors angulaires en aluminium, les balanciers en métal, les couvercles avec un joint d'étanchéité biologique, ainsi que les châssis et les réducteurs peuvent être autoclavés à 121 °C / 250 °F (20 min). En cas de doute, il faut se renseigner auprès du fabricant.



Avant l'autoclavage, déposer le couvercle des rotors et du récipient.

L'autoclavage provoque l'accélération du vieillissement des plastiques et peut provoquer des décolorations des plastiques.

Après le passage à l'autoclave, nous recommandons de remplacer les anneaux d'étanchéité des rotors étanches aux aérosols et aux systèmes de sécurité bio.

### 20.4 Réservoirs de centrifugation

- En cas de fuite ou de rupture de récipients de centrifugation, il faut éliminer tous les morceaux de récipients cassés, les fragments de verre et les substances centrifugées écoulées.
- Les amortisseurs antivibrations ainsi que les caoutchouc intermédiaires des rotors doivent être remplacés après un bris de verre.



Les fragments de verre restants peuvent entraîner d'autres bris de verre !

- S'il s'agit d'un matériau infectieux, exécuter immédiatement une désinfection.



## 21 Défaits

Si l'erreur ne peut pas être éliminée d'après le tableau des dérangements, il faut alors avertir le service après-vente. Vous aurez l'obligeance de mentionner le modèle de centrifugeuse et le numéro d'usine. Les deux sont marqués sur la plaque signalétique de la centrifugeuse.



Effectuer une RÉINITIALISATION DU SECTEUR :

- Couper l'interrupteur de secteur (position de l'interrupteur "0").
- Attendre au moins 10 secondes et refermer ensuite l'interrupteur de secteur (position de l'interrupteur "I").

Erreur	Affichage	Cause	Solution
Pas d'affichage	---	Pas de tension Défaut des fusibles sur l'entrée de secteur.	- Vérifier l'alimentation en tension. - Vérifier les fusibles d'entrée du secteur, voir au chapitre "Changer les fusibles d'entrée de secteur". - Interrupteur du secteur sur MARCHE
Erreur du compteur de vitesse	- 1 -	Défaillance des impulsions de rotation pendant une opération.	- Pour des raisons de sécurité, le couvercle peut seulement être ouvert après env. 120 secondes. - Lorsque cette durée s'est écoulée, effectuer une "RÉINITIALISATION DU SECTEUR".
Reset secteur	- 2 -	Interruption du secteur pendant le cycle de centrifugation. (Le cycle de centrifugation n'est pas terminé.)	- Après l'arrêt, ouvrir le couvercle et actionner touche <b>START</b> . - En cas de besoin, répéter le cycle de centrifugation.
Défaut d'équilibrage	- 3 -	Le rotor est chargé de manière non symétrique.	- Après arrêt du rotor, ouvrir le couvercle. - Vérifier le chargement du rotor, voir au chapitre "Chargement du rotor". - Répéter le cycle de centrifugation.
Communication	- 4 -	Défaut dans l'unité de commande ou capacité.	- Effectuer une RÉINITIALISATION DU SECTEUR après l'immobilisation du rotor.
Surcharge	- 5 -	Moteur ou commande du moteur défectueux.	- Effectuer une RÉINITIALISATION DU SECTEUR après l'immobilisation du rotor.
Surtension ou sous-tension	- 6 - - 8 -	Tension du secteur en dehors des tolérances (voir : Caractéristiques techniques).	- Effectuer une RÉINITIALISATION DU SECTEUR après l'immobilisation du rotor. - Vérifier tension du secteur.
Survitesse	- 7 -	Défaut dans l'unité de capacité.	- Effectuer une RÉINITIALISATION DU SECTEUR après l'immobilisation du rotor.
Surtempérature	- 9 -	Avertisseur de surtempérature dans le moteur a déclenché.	- Après arrêt du rotor, ouvrir le couvercle à l'aide du déverrouillage de secours. (Voir chapitre : Déverrouillage de secours). - Laisser refroidir le moteur.
Versions Error	Un chiffre apparaît dans l'affichage du temps.	Une version erronée de la machine a été introduite. Unité de commande saute au menu ajustage.	- Régler le chiffre 4 avec les touches <b>▲</b> <b>▼</b> situées en dessous de l'affichage du temps. - Appuyer sur la touche <b>STOP</b> pour sauvegarder le réglage. - Effectuer une RÉINITIALISATION DU SECTEUR.
Controller-Watchdog	- C -	Défaut dans l'unité de commande.	- Effectuer une RÉINITIALISATION DU SECTEUR après l'immobilisation du rotor.
Erreur du verrouillage du couvercle	d	Erreur du verrouillage ou de la fermeture du capot.	- Effectuer une RÉINITIALISATION DU SECTEUR après l'immobilisation du rotor.
Court-circuit	- E -	Court-circuit dans l'unité de commande / capacité.	- Effectuer une RÉINITIALISATION DU SECTEUR après l'immobilisation du rotor.
Pas de code du rotor	- F -	Pas de reconnaissance du rotor au démarrage. Pas de rotor en service ou compteur de vitesse défectueux.	- Effectuer une RÉINITIALISATION DU SECTEUR après l'immobilisation du rotor.
Le nouveau rotor est reconnu	rot...	Voir chapitre détection du rotor	- Appuyer sur la touche <b>START</b> .

## 22 Changer les fusibles d'entrée de secteur



Amener le commutateur principal en position arrêt et sectionner la centrifugeuse du secteur !

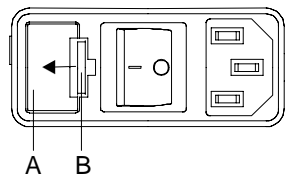

Le porte-fusible (A) avec les fusibles d'entrée de secteur se trouve à côté de l'interrupteur secteur.

- Retirer le câble de raccordement de la prise d'appareil.
- Appuyer la fermeture rapide (B) contre le porte-fusible (A) et extraire celui-ci.
- Remplacer les fusibles d'entrée du réseau défectueux.



N'utilisez que des fusibles avec la valeur nominale, fixée pour le type, voir tableau suivant.

- Remettre en place le porte-fusible et pousser jusqu'à encastrement de la fermeture rapide.
- Rétablir le raccord de la centrifugeuse au secteur.

Modèle	Type	Fusible	N° de commande
ROTOFIX 32 A	1206	T 3.15 AH/250V	E997
ROTOFIX 32 A	1206-01	T 5 AH/250V	E914

## 23 Réparation des centrifugeuses

Dans le cas où la centrifugeuse est expédiée au fabricant pour réparation, elle doit être décontaminée et nettoyée avant expédition, dans le but d'assurer la protection des personnes, de l'environnement et du matériel.

Nous nous réservons le droit de refuser les centrifugeuses contaminées.

Nous facturons au client les frais de nettoyage et de désinfection.

Vous voudrez bien manifester votre compréhension pour cette réglementation.

## 24 Élimination des déchets

Les dispositions légales en vigueur doivent être respectées lors de l'élimination de l'appareil.

Conformément à la directive 2002/96/CE (WEEE), tous les appareils livrés après le 13.08.2005 ne doivent plus être jetés avec les déchets ménagers. L'appareil fait partie du groupe 8 (dispositifs médicaux) et est classé dans le domaine "Business-to-Business".



Le symbole de la poubelle barrée d'une croix indique que l'appareil ne doit pas être jeté avec les déchets ménagers.

Les dispositions relatives à l'élimination des déchets des différents pays de l'UE peuvent varier. Veuillez-vous adresser en cas de besoin à votre fournisseur.

**Indice**

1	Usò previsto .....	44
2	Rischi residui .....	44
3	Dati tecnici .....	44
4	Indicazioni inerenti la sicurezza .....	45
5	Significato dei simboli .....	46
6	Contenuto della fornitura.....	46
7	Disimballo della centrifuga .....	46
8	Messa in funzione.....	46
9	Apertura e chiusura del coperchio .....	47
9.1	Apertura del coperchio.....	47
9.2	Chiusura del coperchio.....	47
10	Installazione e disinstallazione del rotore .....	47
11	Carico del rotore.....	47
12	Elementi di operazione e visualizzazione .....	48
12.1	Simboli del quadro comandi.....	48
12.2	Pulsanti e possibilità di regolazione .....	48
13	Regolazione del livello di frenatura.....	49
14	Regolazione del raggio di centrifugazione.....	49
15	Centrifugazione .....	50
15.1	Centrifugazione con preselezione del tempo .....	50
15.2	Funzionamento continuo.....	50
15.3	Centrifugazione a impulsi.....	50
15.4	Visualizzazione dell'accelerazione centrifuga relativa (RCF) .....	51
16	Accelerazione centrifuga relativa (RCF) .....	51
17	Centrifugazione di materiali con elevata densità .....	51
18	Riconoscimento del rotore.....	51
19	Sblocco di emergenza .....	52
20	Pulizia e manutenzione .....	52
20.1	Centrifuga .....	52
20.2	Rotori ed accessori .....	52
20.2.1	Perni di trascinamento .....	53
20.2.2	Rotori e accessori con durata d'impiego limitata.....	53
20.3	Mantenere in autoclave.....	53
20.4	Contenitori centrifuga .....	53
21	Guasti.....	54
22	Sostituzione fusibili entrata rete.....	55
23	Accettazione di centrifughe da riparare .....	55
24	Smaltimento .....	55
25	Anhang / Appendix .....	56
25.1	Rotoren und Zubehör / Rotors and accessories.....	56

## 1 Uso previsto

La presente macchina è un articolo medicale (centrifuga di laboratorio) ai sensi delle direttive IVD 98/79/CE. La centrifuga separa sostanze e/o miscele di sostanze con una densità max. di 1,2 kg/dm<sup>3</sup>. Sono comprese anche sostanze e miscele di origine umana. La centrifuga deve essere utilizzata unicamente per questo scopo. Qualsiasi altro tipo di utilizzo è improprio. La ditta Andreas Hettich GmbH & Co. KG non risponde dei danni che ne conseguono.

L'uso previsto comporta anche il rispetto di tutte le avvertenze delle istruzioni d'uso e l'esecuzione dei lavori di ispezione e manutenzione stabiliti.

## 2 Rischi residui

La macchina è costruita secondo lo stato della tecnica e le regole tecniche di sicurezze riconosciute. L'utilizzo o il trattamento non conformi possono causare pericoli per la vita e la salute dell'operatore o di terzi e anche danni materiali e alla macchina. La macchina deve essere impiegata solo l'uso previsto e solo in perfetto stato di sicurezza.

Eliminare immediatamente i guasti che possono compromettere la sicurezza.

## 3 Dati tecnici

Costruttore	Andreas Hettich GmbH & Co. KG D-78532 Tuttlingen	
Modello	ROTOFIX 32 A	
Tipo	1206	1206-01
Tensione di rete ( $\pm 10\%$ )	208 – 240 V 1~	100 – 127 V 1~
Frequenza di rete	50 – 60 Hz	50 – 60 Hz
Potenza assorbita	300 VA	300 VA
Assorbimento di corrente	1.4 A	3.0 A
Capacità max.	4 x 100 ml / 32 x 15 ml	
Densità permessa	1.2 kg/dm <sup>3</sup>	
Regime di rotazione (RPM)	6000	
Accelerazione (RCF)	4186	
Energia cinetica	3160 Nm	
Obbligo di collaudo (BGR 261)	no	
Presupposti ambientali (EN 61010-1)	solo in interni fino a 2000 metri sopra il livello del mare 2°C fino a 40°C umidità relativa massima dell'aria 80% per temperature fino a 31°C, con riduzione lineare fino al 50% dell'umidità relativa per una temperatura di 40°C.	
– luogo di installazione		
– altezza		
– temperatura ambiente		
– umidità dell'aria		
– Categoria di sovratensione (IEC 60364-4-443)	II	
– grado di imbrattamento	2	
Classe di protezione	I	
non adatto per l'impiego in ambiente a rischio di esplosione.		
Compatibilità elettromagnetica	FCC Class B	
– emissione di radiointerferenze (schermatura)	EN 55011, gruppo 1, classe B EN 61000-3-2 EN 61000-3-3	
– resistenza alle interferenze	EN 61000-6-2	----
Livello di emissione acustica (in funzione del rotore)	$\leq 57$ dB(A)	
dimensioni		
– larghezza	366 mm	
– profondità	430 mm	
– altezza	257 mm	
Peso	23 kg	

#### 4 Indicazioni inerenti la sicurezza



**Non si possono far valere diritti di garanzia presso il costruttore in caso di mancata osservanza delle presenti indicazioni.**

- **Prima di mettere in funzione la centrifuga si devono leggere ed osservare le istruzioni per l'uso. L'apparecchio può essere utilizzato solo da persone che abbiano letto e compreso le istruzioni d'uso.**
- Oltre alle istruzioni per l'uso, si devono osservare anche i regolamenti, relativi alla protezione antinfortunistica ed i regolamenti tecnici, riconosciuti in materia di sicurezza del lavoro. Le istruzioni per l'uso vanno completate dalle norme nazionali in vigore nel paese d'impiego, relative alla protezione antinfortunistica ed alla tutela ambientale.
- La centrifuga è costruita in base all'attuale livello tecnologico e le regole di sicurezza conosciute.
  - La centrifuga può essere tuttavia fonte di pericolo per l'operatore o per terzi, se non viene utilizzata da personale appositamente addestrato o se viene utilizzata in modo improprio o non conforme alla destinazione.
- La centrifuga deve venire posizionata in modo sicuro.
- Prima di utilizzare la centrifuga, è necessario controllare che il rotore sia correttamente in sede.
- Durante un'operazione di centrifugazione, in una zona di sicurezza di 300 mm attorno alla centrifuga non deve sostare alcuna persona, materiali pericolosi ed oggetti, in conformità alle norme IEC 61010-2-020.
- Durante l'esercizio bisogna evitare di muovere la centrifuga o di urtarvi contro.
- In caso di guasto, ovvero del ripristino d'emergenza, non si deve assolutamente toccare il rotore.
- Quando la centrifuga passa da un ambiente freddo in uno caldo, per evitare danni dovuti alla condensa, lasciar riscaldare la centrifuga per almeno 3 ore nell'ambiente caldo prima di collegarla alla rete, oppure portare la centrifuga a temperatura d'esercizio mettendola in funzione per 30 minuti nell'ambiente freddo.
- Devono essere utilizzati esclusivamente i rotori e gli accessori omologati per questa apparecchiatura (vedere capitolo "Anhang/Appendix, Rotoren und Zubehör/Rotors and accessories").
- Il rotore della centrifuga può essere caricato solo in conformità al capitolo " Carico del rotore".
- In caso di centrifugazione con massimo numero di giri, la densità dei materiali o delle miscele di materiali non deve superare il valore di composizione di  $1,2 \text{ kg/dm}^3$ .
- Non è consentito l'uso di centrifughe non bilanciate in modo regolamentare.
- Non è permesso l'impiego della centrifuga in ambiente a pericolo di esplosione.
- E' proibito l'uso di una centrifuga con:
  - materiali infiammabili od esplosivi
  - materiali che possono reagire chimicamente tra loro con forte energia.
- Se vengono centrifugate sostanze pericolose o miscele di sostanze contaminate da micro organismi tossici, radioattivi o patogeni, l'utente dovrà prendere opportuni provvedimenti in materia. Si devono fondamentalmente utilizzare contenitori per centrifugazione con tappi a vite speciali per sostanze pericolose. Con materiali dei gruppi di rischio 3 e 4, oltre ai contenitori per centrifugazione chiudibili si deve impiegare un sistema di sicurezza biologico (vedi manuale "Laboratory Biosafety Manual" dell'Organizzazione mondiale per la salute).  
 La guarnizione biologica (guarnizione ad anello) di questo sistema di sicurezza biologico impedisce la fuoriuscita delle goccioline e degli aerosol tra la sospensione ed il coperchio.  
 Se la sospensione di un sistema di sicurezza biologico viene usata senza coperchio, la guarnizione ad anello deve essere rimossa dalla sospensione per evitare di danneggiarla durante il ciclo di centrifugazione. Le guarnizioni ad anello danneggiate non possono più essere utilizzate per la chiusura a tenuta del sistema di sicurezza biologico.  
 Senza l'impiego di un sistema di sicurezza biologico, una centrifuga non è microbiologicamente a tenuta in conformità alla norma EN 61010-2-020.  
 Per quanto riguarda i sistemi biologici di sicurezza fornibili, rimandiamo al capitolo "Anhang/Appendix, Rotoren und Zubehör/Rotors and accessories". Nel dubbio chiedere maggiori informazioni al produttore o importatore.
- Non è consentito il funzionamento della centrifuga con sostanze altamente corrosive che possono pregiudicare la resistenza meccanica dei rotori, delle sospensioni e degli accessori.
- I rotori, le sospensioni e gli accessori che presentano forti segni di corrosione o danni meccanici, oppure la cui durata d'impiego è scaduta, non devono più essere utilizzati.
- Gli interventi di riparazione devono essere effettuati esclusivamente da una persona autorizzata dal costruttore.
- Devono essere impiegati solo ed esclusivamente pezzi di ricambio originali ed accessori autorizzati della ditta Andreas Hettich GmbH & Co. KG.
- Sono di validità le seguenti norme di sicurezza: IEC 61010-1 e IEC 61010-2-020 come anche le loro nazionali varianti.
- La sicurezza e l'affidabilità della centrifuga sono garantite solo se:
  - la centrifuga funziona in conformità con le istruzioni per l'uso
  - l'installazione elettrica sul luogo di posizionamento della centrifuga risponde ai requisiti previsti dalla IEC
  - i controlli previsti in base a BGV A1, BGR 261 vengono eseguiti da un perito esperto in materia.

## 5 Significato dei simboli



Simbolo sulla macchina:

Attenzione, punto pericoloso generico.

Prima di utilizzare la centrifuga, è assolutamente necessario leggere le istruzioni d'uso e rispettare le avvertenze relative alla sicurezza!



Simbolo nelle istruzioni per il funzionamento:

Attenzione, punto pericoloso generico.

Questo simbolo contraddistingue le avvertenze relative alla sicurezza e indica situazioni potenzialmente pericolose.

La mancata osservanza di tali avvertenze può causare danni materiali e personali.



Simbolo nelle istruzioni per il funzionamento:

Questo simbolo indica argomenti importanti.



Simbolo sulla macchina e nelle istruzioni d'uso:

Simbolo per la raccolta separata delle apparecchiature elettriche ed elettroniche, in conformità alle direttive 2002/96/CEE (WEEE). L'apparecchiatura appartiene al gruppo 8 (apparecchiature medicali).

Impiego nelle nazioni dell'Unione Europea, in Norvegia ed in Svizzera.

## 6 Contenuto della fornitura

I seguenti accessori vengono forniti con la centrifuga:

- |   |  |
|---|--|
| 1 | cavo elettrico                                   |
| 2 | fusibili (tipo 1206-02: 3 fusibili)              |
| 1 | grasso per perni portanti                        |
| 1 | chiave a forcella                                |
| 1 | chiave di sblocco                                |
| 1 | istruzioni per la sicurezza durante il trasporto |
| 1 | istruzioni per l'uso                             |

Rotore/i e i corrispondenti accessori vengono forniti in base alla commessa.

## 7 Disimballo della centrifuga

- Levare il cartone verso l'alto e togliere l'imbottitura.



Non sollevare dall'impugnatura del coperchio.

Considerare il peso della centrifuga, vedere capitolo "Dati tecnici".

Con il numero adeguato di persone, sollevare la centrifuga da entrambi i lati e riporla sul tavolo di laboratorio.

## 8 Messa in funzione

- In base alla normativa per gli strumenti di laboratorio IEC 61010-2-020 gli impianti domestici devono essere provvisti di apposito sezionatore d'emergenza per l'interruzione della rete in caso di guasto. L'interruttore deve essere posizionato distante dalla centrifuga, preferibilmente al di fuori della stanza in cui è posizionata la centrifuga o vicino all'uscita.
- Togliere la sicura per il trasporto, che si trova sul fondo dell'alloggiamento, vedere foglio avvisi "Sicura per il trasporto".
- Porre la centrifuga in un posto adatto e livellarla. Per l'installazione deve essere rispettata la zona di sicurezza di 300 mm attorno alla centrifuga, richiesta in conformità alle norme IEC 61010-2-020.



Durante un'operazione di centrifugazione, in una zona di sicurezza di 300 mm attorno alla centrifuga non deve sostare alcuna persona, materiali pericolosi ed oggetti, in conformità alle norme IEC 61010-2-020.

- Non posizionare alcun oggetto in prossimità delle griglie di ventilazione. Mantenere un'area di ventilazione di 300 mm, intorno al condotto.
- Verificare se la tensione di rete sia adatta all'indicazione riportata nella targhetta con i dati caratteristici.
- Collegare la centrifuga ad una spina standard di rete tramite il cavo di collegamento. Per la potenza massima assorbita, vedere il capitolo "Dati tecnici".
- Accendere l'interruttore di rete. Posizione di accensione "I". I dati di centrifuga utilizzati per ultimi vengono illustrati.
- Aprire il coperchio.

## 9 Apertura e chiusura del coperchio

### 9.1 Apertura del coperchio



E' possibile aprire il coperchio solo se la centrifuga è accesa ed il rotore è fermo.  
Se non dovesse essere possibile, vedi capitolo "Sblocco di emergenza".

- Tirare verso l'alto la barra d'impugnatura sita sul coperchio. Nell'indicazione di rotazione  si accende il simbolo "L" (coperchio aperto).
- Aprire il coperchio.

### 9.2 Chiusura del coperchio



Non chiudere il coperchio sbattendolo.

- Appoggiare il coperchio e abbassare la barra d'impugnatura sita sul coperchio. Nell'indicazione di rotazione  si accende il simbolo "—" (coperchio chiuso).

## 10 Installazione e disinstallazione del rotore

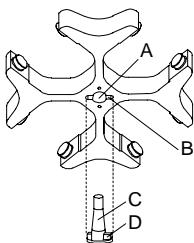

- Pulire l'albero motore (C) ed il foro del rotore (A), successivamente lubrificare leggermente l'albero motore. Particelle di sporco tra l'albero motore ed il rotore impediscono un normale funzionamento del rotore e causano un movimento rumoroso.
- Porre il rotore in senso verticale sull'albero motore. Il meccanismo di trascinamento dell'albero motore (D) deve trovarsi nella scanalatura del rotore (B). Sul rotore è segnato l'allineamento della scanalatura.
- Stringere il dado di registrazione di tensione del rotore con l'aiuto della chiave inclusa nel cartone, ruotandola in senso orario.
- Verificare che il rotore sia fissato.
- Disinstallare il rotore: svitare il dado di registrazione di tensione, ruotandolo in senso anti-orario fino a che non abbia raggiunto il punto di completo svitamento. Con il punto di svitamento completo, il rotore si può smontare dal cono dell'albero motore. Girare il dado di registrazione di tensione fino a che diventi possibile smontare il rotore dall'albero motore.

## 11 Carico del rotore



Lo standard dei recipienti di vetro centrifugati sono da caricare fino a RCF 4000 (DIN 58970 capoverso 2).

- Verificare che il rotore sia fissato.
- Nel caso di rotori oscillanti, tutti i siti del rotore devono essere muniti di ganci **uguali**. Particolari ganci sono contrassegnati con il numero del sito del rotore. Questi ganci devono essere applicati solo nel relativo sito del rotore.
- I rotori ed i ganci devono essere caricati esclusivamente in modo simmetrico. Per le combinazioni permesse vedere capitolo "Anhang/Appendix, Rotoren und Zubehör/Rotors and accessories". In caso di rotori angolari devono essere caricati tutti i possibili siti del rotore, vedere il capitolo "Anhang/Appendix, Rotoren und Zubehör/Rotors and accessories".
- In determinate sospensioni è indicato il peso del carico massimo e il peso massimo della sospensione completamente attrezzata. Questi pesi non devono essere superati. Il peso indicato per il carico massimo comprende il peso completo di riduttore, supporto, provetta da centrifuga e contenuto.
- Nel caso di contenitori con inserimenti in gomma, deve essere sempre mantenuto lo stesso numero di inserimenti in gomma sotto i contenitori di centrifugazione.
- Riempire i recipienti della centrifuga all'esterno della centrifuga stessa.
- Fare attenzione che non giunga alcuna sostanza liquida nella camera di centrifugazione durante il carico ed l'oscillazione dei ganci.
- Il carico massimo dei recipienti della centrifuga non deve essere superiore a quello indicato dalla casa costruttrice.
- Per limitare al massimo le differenze di peso all'interno dei contenitori di centrifugazione, bisogna fare attenzione che siano riempiti tutti in modo uguale.

## 12 Elementi di operazione e visualizzazione

Vedere illustrazione alla pagina 2.

Fig. 2: Display

### 12.1 Simboli del quadro comandi



Indicazione di rotazione. L'indicatore di rotazione si illumina ruotando in senso antiorario fino a che il rotore gira.

All'arresto del rotore, l'indicazione di rotazione visualizza mediante simboli lo stato del coperchio:

Simbolo  : coperchio aperto

Simbolo  : coperchio chiuso



Gli errori di operazione e i guasti sono visualizzati sul display (vedere capitolo "Guasti").

### 12.2 Pulsanti e possibilità di regolazione

#### RPM/RCF x 100



- Velocità di rotazione

Si può regolare un valore numerico da 500 RPM fino alla velocità massima di rotazione del rotore. Per la velocità massima di rotazione del rotore, vedere capitolo "Appendice/Appendix, Rotori e accessori/Rotors and accessories". Regolabile in intervalli di 100 (RPM = valore visualizzato x 100). Tenendo premuto il pulsante  o  il valore cambia a velocità crescente.

- Visualizzare il livello di frenatura e il raggio di centrifugazione.

t



- Tempo ciclo
  - Regolabile da 1 a 99 minuti, in intervalli di 1 minuto
  - Funzionamento continuo "--"

- Raggio di centrifugazione. Immissione in centimetri. Regolabile da 5 a 16 centimetri, in intervalli di 1 centimetro. Per il raggio di centrifugazione, vedere capitolo "Appendice/Appendix, Rotori e accessori/Rotors and accessories".
- Livelli di frenatura 0 o 1. Livello 1 = tempo di arresto breve, livello 0 = tempo di arresto lungo.

Tenendo premuto il pulsante  o  il valore cambia a velocità crescente.



- Avvio del ciclo di centrifugazione.



- Termine del ciclo di centrifugazione. Il rotore si arresta con il livello di frenatura preselezionato.
- Memorizzare il livello di frenatura e il raggio di centrifugazione.



- Indicazione dell'accelerazione centrifuga relativa (RCF). L'accelerazione centrifuga relativa (RCF) viene visualizzata finché si tiene premuto il pulsante .



- Centrifugazione a impulsi. Il ciclo di centrifugazione ha luogo finché si tiene premuto il pulsante .
- Visualizzare il livello di frenatura e il raggio di centrifugazione.



### 13 Regolazione del livello di frenatura

- Disinserire l'interruttore di rete.
- Tenere premuti contemporaneamente il pulsante ▲ al di sotto dell'indicazione della velocità di rotazione e il pulsante (IMPULS).
- Inserire l'interruttore di rete e rilasciare i pulsanti.
- Eventualmente premere il pulsante ▲ al di sotto dell'indicazione della velocità di rotazione finché appare la seguente visualizzazione:

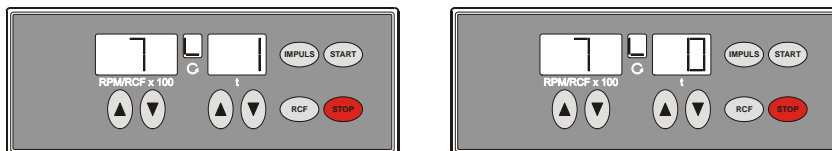

Nell'indicazione della velocità di rotazione viene visualizzata la versione della macchina impostata di fabbrica (p.es. 7) e nell'indicazione del tempo il livello di frenatura impostato.

- Con i pulsanti ▲ ▼ al di sotto dell'indicazione del tempo, regolare il livello di frenatura desiderato. Livello 1 = tempo di arresto breve, livello 0 = tempo di arresto lungo. Per i tempi di arresto, vedere capitolo "Anhang/Appendix, Rotoren und Zubehör/Rotors and accessories".
- Premere il pulsante (STOP) per salvare l'impostazione.

### 14 Regolazione del raggio di centrifugazione

 Il raggio di centrifugazione deve essere immesso in centimetri.

- Disinserire l'interruttore di rete.
- Tenere premuti contemporaneamente il pulsante ▲ al di sotto dell'indicazione della velocità di rotazione e il pulsante (IMPULS).
- Inserire l'interruttore di rete e rilasciare i pulsanti.
- Premere il pulsante ▲ al di sotto dell'indicazione della velocità di rotazione finché appare la seguente visualizzazione:

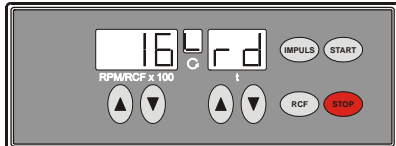

Nell'indicazione della velocità di rotazione viene visualizzato il raggio di centrifugazione impostato.

- Con i pulsanti ▲ ▼ al di sotto dell'indicazione del tempo regolare il raggio di centrifugazione desiderato. Per il raggio di centrifugazione, vedere capitolo "Anhang/Appendix, Rotoren und Zubehör/Rotors and accessories".
- Premere il pulsante (STOP) per salvare l'impostazione.

## 15 Centrifugazione



Durante un'operazione di centrifugazione, in una zona di sicurezza di 300 mm attorno alla centrifuga non deve sostare alcuna persona, materiali pericolosi ed oggetti, in conformità alle norme IEC 61010-2-020.



Se la differenza di peso permissibile nel carico del rotore è superata, l'azionamento si disinserisce durante l'avvio e viene visualizzato l'errore **-3-** (vedere capitolo "Guasti").

Un ciclo di centrifugazione può essere interrotto in qualsiasi momento premendo il pulsante **[STOP]**.

Il tempo e la velocità di rotazione possono essere modificati durante il ciclo di centrifugazione con i pulsanti **[▲]** **[▼]**.

Tenere premuto il pulsante **[▲]** o **[▼]** per modificare il valore a velocità crescente.

Dopo un ciclo di centrifugazione l'indicazione lampeggia fino all'apertura del coperchio o finché un pulsante viene premuto.

Se nell'indicazione di rotazione **⊙** i simboli **"\_"** (coperchio chiuso) e **"L"** (coperchio aperto) lampeggiano alternativamente, è possibile riutilizzare la centrifuga solo dopo aver aperto una volta il coperchio.

Se viene visualizzato **rot xx**, non ha avuto luogo alcun ciclo di centrifugazione a causa di una precedente sostituzione del rotore, vedere capitolo "Riconoscimento del rotore".

- Inserire l'interruttore di rete (posizione interruttore "I").
- Caricare il rotore e chiudere il coperchio della centrifuga.

### 15.1 Centrifugazione con preselezione del tempo

- Con i pulsanti **[▲]** **[▼]** al di sotto dell'indicazione della velocità di rotazione impostare la velocità di rotazione desiderata.
- Con i pulsanti **[▲]** **[▼]** al di sotto dell'indicazione del tempo regolare il tempo desiderato.
- Premere il pulsante **[START]**. L'indicazione di rotazione **⊙** è accesa finché il rotore gira.



Il tempo è visualizzato in minuti. L'ultimo minuto è contato in secondi.  
Se il tempo è visualizzato in minuti, a fianco del numero lampeggia un punto.

- Allo scadere del tempo o in caso di interruzione del ciclo di centrifugazione con il tasto **[STOP]**, il rotore si arresta gradualmente con il livello di frenatura impostato.

Durante il ciclo di centrifugazione sono visualizzati la velocità di rotazione del rotore o il valore RCF risultante e il tempo rimanente.

### 15.2 Funzionamento continuo

- Con i pulsanti **[▲]** **[▼]** al di sotto dell'indicazione della velocità di rotazione impostare la velocità di rotazione desiderata.
- Con il pulsante **[▼]** al di sotto dell'indicazione del tempo azzerare il tempo. Viene visualizzato **"--"**.
- Premere il pulsante **[START]**. L'indicazione di rotazione **⊙** è accesa finché il rotore gira. Il conteggio del tempo inizia da 0.



Il primo minuto è contato in secondi, quindi il tempo è visualizzato in minuti.  
Se il tempo è visualizzato in minuti, a fianco del numero lampeggia un punto.

- Premere il pulsante **[STOP]** per terminare il ciclo di centrifugazione. Il rotore si arresta gradualmente con il livello di frenatura impostato.

Durante il ciclo di centrifugazione sono visualizzati la velocità di rotazione del rotore o il valore RCF risultante e il tempo trascorso.

### 15.3 Centrifugazione a impulsi

- Con i pulsanti **[▲]** **[▼]** al di sotto dell'indicazione della velocità di rotazione impostare la velocità di rotazione desiderata.
- Tenere premuto il pulsante **[IMPULS]**. L'indicazione di rotazione **⊙** è accesa finché il rotore gira. Il conteggio del tempo inizia da 0.



Il primo minuto è contato in secondi, quindi il tempo è visualizzato in minuti.  
Se il tempo è visualizzato in minuti, a fianco del numero lampeggia un punto.

- Rilasciare il pulsante **[IMPULS]** per terminare il ciclo di centrifugazione. Il rotore si arresta gradualmente con il livello di frenatura impostato.

Durante il ciclo di centrifugazione sono visualizzati la velocità di rotazione del rotore e il tempo trascorso.

#### 15.4 Visualizzazione dell'accelerazione centrifuga relativa (RCF)

Durante il ciclo di centrifugazione è possibile visualizzare l'accelerazione centrifuga relativa (RCF).

 Se si utilizza l'accelerazione centrifuga relativa (RCF), è necessario immettere il raggio di centrifugazione.

- Durante il ciclo di centrifugazione tenere premuto il pulsante **[RCF]**.  
L'accelerazione centrifuga relativa (RCF) appare nell'indicazione della velocità di rotazione (RCF = valore visualizzato x 100).
- Rilasciare il pulsante **[RCF]**. È nuovamente visualizzata la velocità di rotazione.

#### 16 Accelerazione centrifuga relativa (RCF)

L'accelerazione centrifuga relativa (RCF) è indicata come un multiplo dell'accelerazione terrestre (g). È un valore numerico privo di unità e funge per paragonare le prestazioni di separazione e sedimentazione.

Il calcolo viene eseguito in base alla formula:

$$RCF = \left( \frac{RPM}{1000} \right)^2 \times r \times 1,118 \quad \Rightarrow \quad RPM = \sqrt{\frac{RCF}{r \times 1,118}} \times 1000$$

RCF = accelerazione centrifuga relativa

RPM = numero dei giri

r = raggio di centrifugazione in mm = distanza dal centro dell'asse di rotazione fino al fondo del recipiente di centrifugazione. Raggio di centrifugazione vedi al capitolo "Anhang/Appendix, Rotoren und Zubehör/Rotors and accessories".

 L'accelerazione centrifuga relativa (RCF) dipende dal numero dei giri e dal raggio di centrifugazione.

#### 17 Centrifugazione di materiali con elevata densità

I rotori sono costruiti in modo da poter centrifugare delle sostanze dalla densità mediamente omogenea di max. 1,2 kg/dm<sup>3</sup>, con il numero di giri indicato.

Sostanze di maggiore densità devono essere centrifugate con un numero di giri ridotto.

Il numero di giri consentito si calcola con la formula seguente:

$$\text{numero di giri ridotto (n}_{\text{red}}) = \sqrt{\frac{1,2}{\text{densità maggiore}}} \times \text{numero di giri nominale}$$

p.es.: RPM 4000, densità 1,6 kg/dm<sup>3</sup>

$$n_{\text{red}} = \sqrt{\frac{1,2}{1,6}} \times 4000 = 3464 \text{ RPM}$$

In caso di dubbio, rivolgersi al costruttore per maggiori informazioni.

#### 18 Riconoscimento del rotore

Con l'inizio di ogni corsa di centrifugazione, avviene il riconoscimento del rotore installato.

Dopo una sostituzione del rotore, l'azionamento si disinserisce e viene visualizzato il codice (rot xx) del rotore.

- Premere il tasto **[START]**. I dati di centrifuga utilizzati per ultimi vengono illustrati.

 L'ulteriore utilizzo della centrifuga è possibile solo dopo avere aperto una volta il coperchio.  
Se dopo un cambio del rotore il numero di giri massimo del rotore è inferiore al numero di giri impostato, la velocità viene limitata al numero di giri massimo del rotore.

## 19 Sblocco di emergenza

In caso di mancanza di corrente non si può aprire il coperchio. Deve essere effettuata manualmente uno sblocco di emergenza.



Per lo sblocco di emergenza, disconnettere la centrifuga dalla rete elettrica.  
 Aprire il coperchio solo con l'arresto del rotore.  
 Per lo sblocco di emergenza si può usare solo la chiave di sbocco di plastica in dotazione.

Vedere illustrazione alla pagina 2.

- Disinserire l'interruttore di rete (posizione interruttore "0").
- Guardare attraverso la finestra presente nel coperchio per assicurarsi che il rotore sia fermo.
- Introdurre il perno di sblocco (vedi materiale fornito) orizzontalmente nel foro (Fig. 1, A). Spingere in dentro la spina di sbloccaggio fino a quando, premendo verso il basso la spina, la maniglia si lascia girare verso l'alto.
- Aprire il coperchio.

## 20 Pulizia e manutenzione



Prima della pulizia, staccare la presa di corrente.  
 Prima di iniziare un procedimento di pulizia e decontaminazione diverso da quello consigliato dal produttore, l'utilizzatore deve accertarsi presso il produttore che tale procedimento previsto non rechi danno all'apparecchio.

- Devono essere impiegati detersivi e disinfettanti con valore PH compreso tra 5 e 8. Evitare detersivi alcalini con valore PH superiore di 8.
- Seguire attentamente le indicazioni speciali del produttore sull'impiego di detersivi e disinfettanti, al fine di evitare qualsiasi fenomeno di corrosione.

### 20.1 Centrifuga

- Pulire regolarmente il corpo della centrifuga e la camera di centrifugazione e impiegare all'occorrenza sapone o un detergente delicato e un panno umido. Ciò serve da un lato per l'igiene e dall'altro lato per evitare la corrosione causata da impurità incrostate.
- In caso di formazione di acqua di condensa, asciugare la camera di centrifugazione pulendola con un panno assorbente.
- In presenza di materiale infettivo nella camera di centrifugazione si deve disinfettarla immediatamente. Per la disinfezione delle superfici raccomandiamo Bacillol® Plus della ditta Bode Chemie Hamburg o Biocidal ZF™ della ditta WAK-Chemie Medical GmbH Steinbach.
- Lubrificare leggermente la guarnizione in gomma della camera di centrifugazione dopo averla pulita.

### 20.2 Rotori ed accessori

- Per evitare che il materiale si corroda o subisca variazione, i rotor e i pezzi accessori devono essere puliti regolarmente con sapone o un detergente delicato e un panno umido. Si consiglia una pulizia settimanale oppure meglio dopo ogni utilizzo.
- In caso di sporco costituito da materiale patogeno o radioattivo nel rotore o nelle parti accessorie, bisogna effettuare una pulizia idonea. Per la disinfezione si raccomanda Helipur® H plus N della ditta B. Braun Melsungen. Per la rimozione di materiale radioattivo si raccomanda decon neutracon® della ditta Decon Laboratories Limited.
- Dopo la pulizia, i rotor e le parti accessorie devono essere immediatamente asciugati.
- I rotor ad angolo, i contenitori e i supporti in alluminio devono essere ingrassati leggermente con grasso privo d'acidi come ad esempio vaselina quando sono ben asciutti.
- In caso di rotor a tenuta di aerosol e di sistemi di Bio-Sicurezza (vedi capitolo "Anhang/Appendix, Rotoren und Zubehör/Rotors and accessories"), gli anelli di tenuta devono essere controllati e puliti regolarmente (settimanalmente). In presenza di crepe, parti fragili o logorio, l'anello di tenuta deve essere subito sostituito. Per evitare una distorsione dell'anello di guarnizione durante l'apertura e la chiusura del coperchio, l'anello delle guarnizione deve essere ingrassato con grasso privo di acidi, come ad esempio vaselina.
- Per evitare la corrosione causata dall'umidità tra il rotore e l'albero motore, si deve provvedere almeno una volta al mese di smontare il rotore, pulirlo e di lubrificare leggermente l'albero motore.
- Bisogna verificare mensilmente che i rotor e le parti accessorie non siano danneggiati dalla corrosione.



Rotori ed accessori non devono essere più utilizzati se presentano consumo o corrosione.

- Verificare settimanalmente la posizione del rotore.

### 20.2.1 Perni di trascinamento

In rotori oscillanti, i perni di trascinamento devono essere lubrificati regolarmente (Grasso lubrificante Hettich no. d'ord. 4051) per consentire un'oscillazione equilibrata dei ganci.

### 20.2.2 Rotori e accessori con durata d'impiego limitata

L'impiego di determinati rotori, sospensioni ed accessori è limitato nel tempo.

Questi sono contrassegnati con la data di scadenza, per esempio: "einsetzbar bis Ende: / usable until end of: IV. Quartal 2011" (utilizzabile fino a fine: IV° trimestre 2011).



Una volta raggiunta la relativa data di scadenza indicata, per motivi di sicurezza i rotori, le sospensioni e gli accessori non devono più essere utilizzati.

### 20.3 Mantenere in autoclave

I rotori basculanti, i rotori angolari di alluminio, le sospensioni di metallo, i coperchi con chiusura ermetica anti-contaminazione biologica, come pure i telai e le riduzioni possono essere trattati in autoclave a 121° C / 250° F (20 minuti).

In caso di dubbio occorre informarsi presso la casa produttrice.



Il coperchio del rotore ed il contenitore devono essere staccati prima di essere riposti in autoclave.

La conservazione in autoclave accelera il processo di invecchiamento del materiale in plastica. Inoltre può causare variazioni di colore nel materiale in plastica.

Dopo il trattamento in autoclave, consigliamo di sostituire gli anelli di guarnizione dei rotori ermetici all'aerosol e dei sistemi di sicurezza biologici.

### 20.4 Contenitori centrifuga

- In caso di mancanza di tenuta o dopo la rottura dei contenitori per centrifugazione, rimuovere completamente i frammenti dei contenitori, le schegge di vetro e il centrifugato fuoriuscito.
- Dopo la rottura di parti in vetro, sostituire gli inserti di gomma e i manicotti di plastica dei rotori.



Le schegge di vetro rimaste causano ulteriori rotture!

- Nel caso di materiale infettivo, bisogna provvedere immediatamente ad una disinfezione.

## 21 Guasti

Se non si riesce a eliminare l'errore seguendo le indicazioni della tabella guasti, informare il servizio assistenza clienti.

Pregasi comunicare il tipo di centrifuga ed il numero di fabbricazione che sono riportati nella targhetta con i dati caratteristici della centrifuga.

	<p>Esecuzione di un RESET RETE:</p> <ul style="list-style-type: none"> <li>- Disinserire l'interruttore di rete (posizione interruttore "0").</li> <li>- Attendere almeno 10 secondi quindi reinserire l'interruttore di rete (posizione interruttore "1").</li> </ul>
---	--

Guasto	Indicatore	Causa dell'errore	Eliminazione
Nessun indicatore	---	Assenza di tensione Scatto del fusibile di sicurezza per sovracorrente.	<ul style="list-style-type: none"> <li>- Controllare la tensione di alimentazione.</li> <li>- Controllare i fusibili di ingresso di rete, vedere il capitolo "Sostituzione fusibili entrata rete".</li> <li>- Interruttore generale ACCESO.</li> </ul>
Errore del tachimetro	- 1 -	Mancanza degli impulsi del numero di giri durante il funzionamento.	<ul style="list-style-type: none"> <li>- Per motivi di sicurezza, il coperchio si apre solo dopo ca. 120 secondi.</li> <li>- Allo scadere di questo periodo, eseguire un RESET RETE.</li> </ul>
Reset di rete	- 2 -	Interruzione di rete durante il ciclo di centrifugazione. (Il ciclo di centrifugazione non viene terminato.)	<ul style="list-style-type: none"> <li>- Dopo una fase di inattività aprire il coperchio ed azionare il tasto <b>(START)</b>.</li> <li>- All'occorrenza ripetere il ciclo di centrifugazione.</li> </ul>
Squilibrio	- 3 -	Il rotore è caricato in modo non uniforme.	<ul style="list-style-type: none"> <li>- Aprire il coperchio dopo una fase di inattività del rotore.</li> <li>- Controllare il caricamento del rotore, vedere il capitolo "Carico del rotore".</li> <li>- Ripetere il ciclo di centrifugazione.</li> </ul>
Comunicazione	- 4 -	Errore nel modulo di comando o potenza.	<ul style="list-style-type: none"> <li>- Dopo l'arresto del rotore eseguire un RESET RETE.</li> </ul>
Sovraccarico	- 5 -	Motore o comandi del motore difettosi.	<ul style="list-style-type: none"> <li>- Dopo l'arresto del rotore eseguire un RESET RETE.</li> </ul>
Sovratensione Sottotensione	- 6 - - 8 -	Tensione di rete oltre le tolleranze (vedi dati tecnici).	<ul style="list-style-type: none"> <li>- Dopo l'arresto del rotore eseguire un RESET RETE</li> <li>- Controllare la tensione di rete.</li> </ul>
N° giri eccedente	- 7 -	Errore nel comando.	<ul style="list-style-type: none"> <li>- Dopo l'arresto del rotore eseguire un RESET RETE.</li> </ul>
Sovratemperatura	- 9 -	Il termostato di massima nel motore è scattato.	<ul style="list-style-type: none"> <li>- Dopo una fase di inattività del rotore, aprire il coperchio mediante lo sbloccaggio di emergenza (vedi capitolo Sbloccaggio di emergenza).</li> <li>- Far raffreddare il motore.</li> </ul>
Errore di versione	Nell'indicatore del tempo viene indicato un numero.	Impostata una versione errata della macchina, il modulo di comando salta al menu di regolazione.	<ul style="list-style-type: none"> <li>- Con i tasti   presenti sotto l'indicatore impostare il numero 4.</li> <li>- Premere il pulsante <b>(STOP)</b> per salvare l'impostazione.</li> <li>- Esecuzione di un RESET RETE.</li> </ul>
Controller-Watchdog	- C -	Errore nel modulo di comando.	<ul style="list-style-type: none"> <li>- Dopo l'arresto del rotore eseguire un RESET RETE.</li> </ul>
Errore nella chiusura del coperchio.	- d -	Errore blocco coperchio, ovvero chiusura coperchio.	<ul style="list-style-type: none"> <li>- Dopo l'arresto del rotore eseguire un RESET RETE.</li> </ul>
Corto circuito	- E -	Corto circuito nel modulo di comando / potenza.	<ul style="list-style-type: none"> <li>- Dopo l'arresto del rotore eseguire un RESET RETE.</li> </ul>
Nessun codice di rotore	- F -	Nessuna identificazione del rotore all'avvio. Nessun rotore installato o tachimetro difettoso.	<ul style="list-style-type: none"> <li>- Dopo l'arresto del rotore eseguire un RESET RETE.</li> </ul>
Identificazione nuovo rotore	rot...	Vedi capitolo identificazione sul rotore	<ul style="list-style-type: none"> <li>- Premere il pulsante <b>(START)</b>.</li> </ul>

## 22 Sostituzione fusibili entrata rete



Disattivare l'interruttore di rete e sezionare la centrifuga dalla rete!

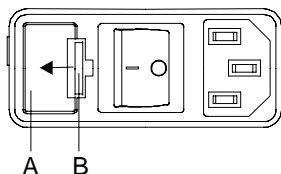

Il portafusibili (A) con i fusibili d'entrata rete si trova accanto all'interruttore di rete.

- Estrarre il cavo di collegamento dalla spina.
- Premere la chiusura a scatto (B) contro il portafusibili (A) ed estrarre quest'ultimo.
- Sostituire i fusibili di rete difettosi.



Utilizzate solo fusibili con valori nominali fissati per il rispettivo tipo, vedere la successiva tabella.

- Inserire di nuovo il portafusibili fino a far scattare la chiusura.
- Collegare di nuovo alla rete la centrifuga.

Modello	Tipo	Fusibile	N° ord.
ROTOFIX 32 A	1206	T 3.15 AH/250V	E997
ROTOFIX 32 A	1206-01	T 5 AH/250V	E914

## 23 Accettazione di centrifughe da riparare

Nel caso in cui la centrifuga debba essere rispedita al produttore per una eventuale riparazione, prima della spedizione deve essere decontaminata e pulita a fondo a salvaguardia delle persone, dell'ambiente e del materiale. Ci riserviamo di accettare centrifughe contaminate. Eventuali costi di pulizia e disinfezione verranno fatturati al cliente. Contiamo a questo riguardo sulla vostra comprensione.

## 24 Smaltimento

Per lo smaltimento dell'apparecchio osservare le rispettive norme di legge.

Ai sensi della direttiva 2002/96/CE (RAEE) tutti gli apparecchi forniti dopo il 13/08/2005 non possono più essere smaltiti con i rifiuti domestici. Questo apparecchio appartiene alla categoria 8 (Dispositivi medicali) ed è classificato nel settore Business-to-Business.







Il simbolo della pattumiera cancellata con una croce indica che l'apparecchio non deve essere smaltito con i rifiuti domestici.

Le norme per lo smaltimento possono essere differenti nei singoli paesi UE. In caso di necessità rivolgersi al proprio rivenditore.

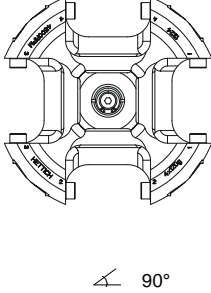
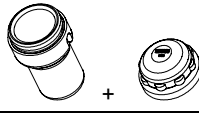
25 Anhang / Appendix

25.1 Rotoren und Zubehör / Rotors and accessories

1324		1390 + 1382							
<p><b>Ausschwingrotor 4-fach / Swing out rotor 4-times</b></p>  <p>90°</p>									
		mit Bioabdichtung / with bio-containment 5)							
		<b>Reduzierung / adapter</b>							
		0761	0765	1329				1329	1330
		<b>Röhrchen / tube</b>							
	0526	0534 4)	0535	0500	0507	Sarstedt		Sarstedt	0519
Kapazität / capacity	ml	100	30	9	15	7,5 - 8,2	9 - 10	10	25
Maße / dimensions	Ø x L mm	44 x 100	44 x 105	14 x 100	17 x 100	15 x 92	16 x 92	15 x 102	24 x 100
Anzahl p. Gestell / number p. frame		1	1	4	4	4	4	4	1
Anzahl p. Rotor / number p. rotor		4	4	16	16	16	16	16	4
Drehzahl / speed	RPM	4000	4000	4000	4000	4000	4000	4000	4000
RZB / RCF		2522	2504	2504	2504	2504	2504	2630	2397
Radius / radius	mm	141	140	140	140	140	140	147	134
 9 (97%)	sec	27	27	27	27	27	27	27	27
 9	sec	30	30	30	30	30	30	30	30
 0	sec	420	420	420	420	420	420	420	420
Probenerwärmung / Sample temp. rise	K 1)	10	10	10	10	10	10	10	10

1) Probenerwärmung bei maximaler Drehzahl und 1 Stunde Laufzeit (nur bei Zentrifuge ohne Kühlung)

4) nicht mit Stopfen zentrifugierbar, Skal. 10µl-300µl, 15ml, 30ml









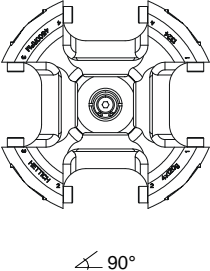
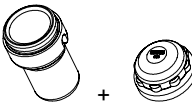
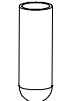

5) Nach DIN EN 61010, Teil 2 – 020. Die Hinweise für Bio-Sicherheitssysteme in den Kapiteln "Sicherheitshinweise" und "Pflege und Wartung" beachten

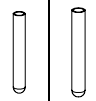



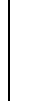
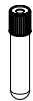



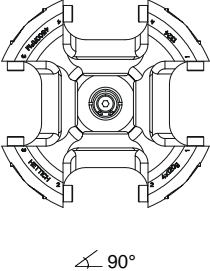
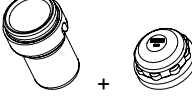
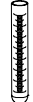
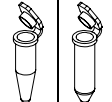

1) Sample temp. rise during maximum speed and 1 hour running time (only with centrifuges without cooling)

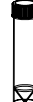
4) can not be centrifugated when plug is attached, Scal. 10µl-300µl, 15ml, 30ml

5) in conformity with DIN EN 61010, part 2 – 020. Observe the notes for bio safety systems in chapters "Notes on safety" and "Maintenance and servicing".



1324		1390 + 1382								
<p><b>Ausschwingrotor 4-fach / Swing out rotor 4-times</b></p>  <p>∠ 90°</p>										
		mit Bioabdichtung / with bio-containment 5)								
		<b>Reduzierung / adapter</b>								
		1331	1339	1343	1347	1348				
		<b>Röhrchen / tube</b>								
0521	Rhesus			0509				Vacutainer	Vacutainer	
										
Kapazität / capacity ml	50	1	3	4	15	10	8	8,5 - 10	4 - 7	
Maße / dimensions Ø x L mm	34 x 100	6 x 45	10 x 60	10 x 88	17 x 120	16 x 80	16 x 81	16 x 100	16 x 75	
Anzahl p. Gestell/number p. frame	1	27	9		1	4	4	4	4	
Anzahl p. Rotor / number p. rotor	4	108	36		4	16	16	16	16	
Drehzahl / speed RPM	4000	4000	4000		4000	4000	4000	4000	4000	
RZB / RCF	2379	2558	2594		2630	2486	2486	2486	2486	
Radius / radius mm	133	143	145		147	139	139	139	139	
 9 (97%) sec	27	27	27		27	27	27	27	27	
 9 sec	30	30	30		30	30	30	30	30	
 0 sec	420	420	420		420	420	420	420	420	
Probenerwärmung/Sample temp. rise K <sup>1)</sup>	10	10	10		10	10	10	10	10	











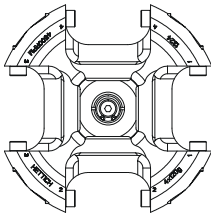
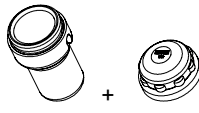



1324		1390 + 1382								
<p><b>Ausschwingrotor 4-fach / Swing out rotor 4-times</b></p>  <p>∠ 90°</p>										
		mit Bioabdichtung / with bio-containment 5)								
		<b>Reduzierung / adapter</b>								
		1329	1351	1363	1365	1383				
		<b>Röhrchen / tube</b>								
0518	2078	0536					0501	Sarstedt		
										
Kapazität / capacity ml	15	1,5	2,0	25	30	5	6	7	2,7 - 3	
Maße / dimensions Ø x L mm	17 x 100	11 x 38	25 x 90	25 x 110	12 x 75	12 x 82	12 x 100	11 x 66		
Anzahl p. Gestell/number p. frame	4	5	1	1	5	5	5	5		
Anzahl p. Rotor / number p. rotor	16	20	4	4	20	20	20	20		
Drehzahl / speed RPM	4000	4000	4000	4000	4000	4000	4000	4000		
RZB / RCF	2504	2415	2308	2630	2522	2522	2522	2522		
Radius / radius mm	140	135	129	147	141	141	141	141		
 9 (97%) sec	27	27	27	27	27	27	27	27		
 9 sec	30	30	30	30	30	30	30	30		
 0 sec	420	420	420	420	420	420	420	420		
Probenerwärmung/Sample temp. rise K <sup>1)</sup>	10	10	10	10	10	10	10	10		











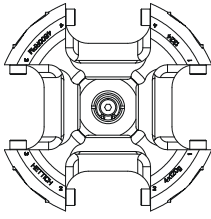
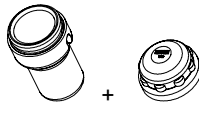







1) Probenerwärmung bei maximaler Drehzahl und 1 Stunde Laufzeit (nur bei Zentrifuge ohne Kühlung)

5) Nach DIN EN 61010, Teil 2 – 020. Die Hinweise für Bio-Sicherheitssysteme in den Kapiteln "Sicherheitshinweise" und "Pflege und Wartung" beachten

1) Sample temp. rise during maximum speed and 1 hour running time (only with centrifuges without cooling)

5) in conformity with DIN EN 61010, part 2 – 020. Observe the notes for bio safety systems in chapters "Notes on safety" and "Maintenance and servicing".

1324		1390 + 1382															
<p><b>Ausschwingrotor 4-fach / Swing out rotor 4-times</b></p>  <p>∠ 90°</p>																	
		mit Bioabdichtung / with bio-containment 5)															
		<b>Reduzierung / adapter</b>															
		1383		1384		1396											
																	
		Sarstedt	Sarstedt	Sarstedt	Vacutainer	Vacutainer	0513	0547	0549								
																	
Kapazität / capacity	ml	2,6 – 2,9	4,9	4,5 - 5	1,6 -5	4 –7	50	85	85								
Maße / dimensions	∅ x L mm	13 x 65	13 x 90	11 x 92	13 x 75	13 x 100	29 x 115	38 x 106	38 x 106								
Anzahl p. Gestell/number p. frame		5	5	5	5	5	1	1	1								
Anzahl p. Rotor / number p. rotor		20	20	20	20	20	4	4	4								
Drehzahl / speed	RPM	4000	4000	4000	4000	4000	4000	4000	4000								
RZB / RCF		2522	2522	2522	2522	2522	2630	2576	2576								
Radius / radius	mm	141	141	141	141	141	147	144	144								
 9 (97%)	sec	27	27	27	27	27	27	27	27								
 9	sec	30	30	30	30	30	30	30	30								
 0	sec	420	420	420	420	420	420	420	420								
Probenerwärmung/Sample temp. rise	K <sup>1)</sup>	10	10	10	10	10	10	10	10								











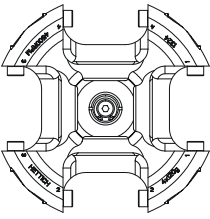





1324		1390 + 1382													
<p><b>Ausschwingrotor 4-fach / Swing out rotor 4-times</b></p>  <p>∠ 90°</p>															
		mit Bioabdichtung / with bio-containment 5)													
		<b>Reduzierung / adapter</b>													
		1459		4416		4417		6311		6318		1356		1457	
															
		Sarstedt	Sarstedt	0546	0545	----	Falcon	0509	Sarstedt						
															
Kapazität / capacity	ml	4 – 5,5	7,5 – 8,2	50	30	12	50	15	1,1 – 1,4						
Maße / dimensions	∅ x L mm	15 x 75	15 x 92	29 x 107	26 x 95	17 x 100	29 x 115	17 x 120	8 x 66						
Anzahl p. Gestell/number p. frame		4	4	1	1	1	1	3	7						
Anzahl p. Rotor / number p. rotor		16	16	4	4	4	4	12	28						
Drehzahl / speed	RPM	4000	4000	4000	4000	4000	4000	4000	4000						
RZB / RCF		2540	2540	2594	2415	2630	2630	2630	2540						
Radius / radius	mm	142	142	145	135	147	147	147	142						
 9 (97%)	sec	27	27	27	27	27	27	27	27						
 9	sec	30	30	30	30	30	30	30	30						
 0	sec	420	420	420	420	420	420	420	420						
Probenerwärmung/Sample temp. rise	K <sup>1)</sup>	10	10	10	10	10	10	10	10						









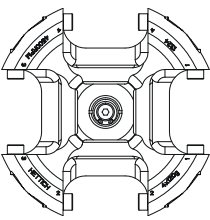

1) Probenerwärmung bei maximaler Drehzahl und 1 Stunde Laufzeit (nur bei Zentrifuge ohne Kühlung)

5) Nach DIN EN 61010, Teil 2 – 020. Die Hinweise für Bio-Sicherheitssysteme in den Kapiteln "Sicherheitshinweise" und "Pflege und Wartung" beachten

1) Sample temp. rise during maximum speed and 1 hour running time (only with centrifuges without cooling)











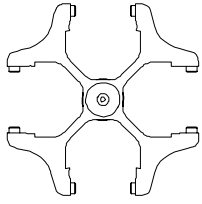



5) in conformity with DIN EN 61010, part 2 – 020. Observe the notes for bio safety systems in chapters "Notes on safety" and "Maintenance and servicing".



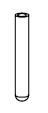

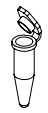





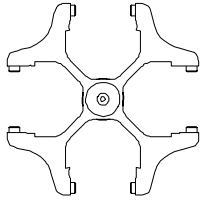

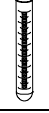
1324		1398								
<b>Ausschwingrotor 4-fach / Swing out rotor 4-times</b>    										
		<b>Reduzierung / adapter</b>								
		1482								
		2 x 	2 x 							
	Sarstedt	Sarstedt	Sarstedt	Sarstedt		Vacutainer	0500	0507		
										
Kapazität / capacity	ml	2,6 – 2,9	4 – 4,5	9 – 10	10	12	4 - 7	9	15	
Maße / dimensions	Ø x L	mm	13 x 65	15 x 75	16 x 92	15 x 102	17 x 100	16 x 75	14 x 100	17 x 100
Anzahl p. Gestell/number p. frame		4	4	4	4	4	4	4	4	
Anzahl p. Rotor / number p. rotor		16	16	16	16	16	16	16	16	
Drehzahl / speed	RPM	4000	4000	4000	4000	4000	4000	4000	4000	
RZB / RCF		2272	2272	2522	2522	2522	2397	2522	2522	
Radius / radius	mm	127	127	141	141	141	134	141	141	
 9 (97%)	sec	27	27	27	27	27	27	27	27	
 9	sec	30	30	30	30	30	30	30	30	
 0	sec	420	420	420	420	420	420	420	420	
Probenerwärmung/Sample temp. rise	K <sup>1)</sup>	9	9	9	9	9	9	9	9	

1324		1398								
<b>Ausschwingrotor 4-fach / Swing out rotor 4-times</b>    										
		<b>Reduzierung / adapter</b>								
		1483	1484	1484	1482					
			ohne / without E2110							
	0509	Falcon	0513	0518						
										
Kapazität / capacity	ml	15	50	50	15					
Maße / dimensions	Ø x L	mm	17 x 120	29 x 115	29 x 115	17 x 100				
Anzahl p. Gestell/number p. frame		4	1	1	4					
Anzahl p. Rotor / number p. rotor		16	4	4	16					
Drehzahl / speed	RPM	4000	4000	4000	4000					
RZB / RCF		2612	2576	2576	2522					
Radius / radius	mm	146	144	144	141					
 9 (97%)	sec	27	27	27	27					
 9	sec	30	30	30	30					
 0	sec	420	420	420	420					
Probenerwärmung/Sample temp. rise	K <sup>1)</sup>	9	9	9	9					

1) Probenerwärmung bei maximaler Drehzahl und 1 Stunde Laufzeit (nur bei Zentrifuge ohne Kühlung)











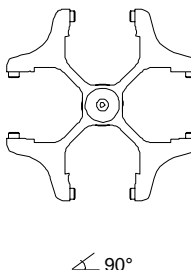
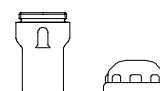







1) Sample temp. rise during maximum speed and 1 hour running time (only with centrifuges without cooling)











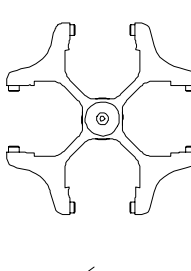
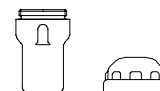



1624		1366								
<b>Ausschwingrotor 4-fach / Swing out rotor 4-times</b>    		1308	1345	1346						
		Reduzierung / adapter								
					1326	1327	1357	5277		
Röhrchen / tube										
	0521					Rhe- sus		2078	0536	
										
Kapazität / capacity	ml	50	45	20	4	3	1	0,4	1,5	2,0
Maße / dimensions	∅ x L	mm	34 x 100	31 x 100	21 x 100	12 x 60	10 x 60	6 x 45	11 x 38	
Anzahl p. Gestell/number p. frame		1	1	2	12	12	30	9		
Anzahl p. Rotor / number p. rotor		4	4	8	48	48	120	36		
Drehzahl / speed	RPM	4000	4000	4000	4000	4000	4000	4000	4000	
RZB / RCF		2290	2361	2361	1932	1932	1950	1968	1968	
Radius / radius	mm	128	132	132	108	108	109	110	110	
 (97%)	sec	22	22	22	22	22	22	22	22	
	sec	25	25	25	25	25	25	25	25	
	sec	110	110	110	110	110	110	110	110	
Probenerwärmung/Sample temp. rise	K <sup>1)</sup>	10	10	10	10	10	10	10	10	

1624		1369			1369-92		1370	1372	1369-91		
<b>Ausschwingrotor 4-fach / Swing out rotor 4-times</b>    											
		Reduzierung / adapter									
								mit Dekantierhilfe / with decanter aid		mit Dekantierhilfe / with decanter aid	
Röhrchen / tube											
	0507	0518	Vacutainer	0501	0578	0500					
											
Kapazität / capacity	ml	15	15	8,5 - 10	6	7	9	5	5		
Maße / dimensions	∅ x L	mm	17 x 100	17 x 100	16 x 100	12 x 82	12 x 100	14 x 100	12 x 75	12 x 75	
Anzahl p. Gestell/number p. frame		4	4	4	4	4	5	17	4		
Anzahl p. Rotor / number p. rotor		16	16	16	16	16	20	68	16		
Drehzahl / speed	RPM	4000	4000	4000	4000	4000	4000	4000	4000		
RZB / RCF		2308	2308	2308	2308	2308	2308	2164	2057		
Radius / radius	mm	129	129	129	129	129	129	121	115		
 (97%)	sec	22	22	22	22	22	22	22	22		
	sec	25	25	25	25	25	25	25	25		
	sec	110	110	110	110	110	110	110	110		
Probenerwärmung/Sample temp. rise	K <sup>1)</sup>	9	9	9	9	9	10	10	9		

1) Probenerwärmung bei maximaler Drehzahl und 1 Stunde Laufzeit

1) Sample temp. rise during maximum speed and 1 hour running time

1624		1381 + 1382											
<p><b>Ausschwingrotor 4-fach / Swing out rotor 4-times</b></p>  <p>∠ 90°</p>		 mit Bioabdichtung / with bio-containment 5)											
		<b>Reduzierung / adapter</b>											
		1329		1330		1331		1339		1343		1347	
													
		<b>Röhrchen / tube</b>											
		0500	0507	Sarstedt		0519	0521	Rhe- sus				0509	
													
Kapazität / capacity	ml	9	15	7,5 - 8,2	9 - 10	25	50	1	0,4	3	4	15	
Maße / dimensions Ø x L	mm	14 x 100	17 x 100	15 x 92	16 x 92	24 x 100	34 x 100	6 x 45		10 x 60/	10 x 88	17 x 120	
Anzahl p. Gestell/number p. frame		4	4	4		1	1	27		9		1	
Anzahl p. Rotor / number p. rotor		16	16	16		4	4	108		36		4	
Drehzahl / speed	RPM	4000	4000	4000		4000	4000	4000		4000		4000	
RZB / RCF		2540	2540	2540		2433	2415	2594		2630		2665	
Radius / radius	mm	142	142	142		136	135	145		147		149	
 (97%)	sec	22	22	22		22	22	22		22		22	
 1	sec	25	25	25		25	25	25		25		25	
 0	sec	110	110	110		110	110	110		110		110	
Probenerwärmung/Sample temp. rise	K <sup>1)</sup>	10	10	10		10	10	10		10		10	











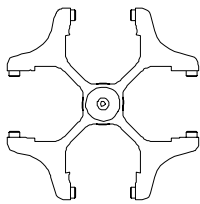

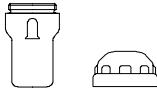

1624		1381 + 1382									
<p><b>Ausschwingrotor 4-fach / Swing out rotor 4-times</b></p>  <p>∠ 90°</p>		 mit Bioabdichtung / with bio-containment 5)									
		<b>Reduzierung / adapter</b>									
		1348				1351		1329		1329	
								ohne Gummieinlage / without rubber insert			
		<b>Röhrchen / tube</b>									
				Vacutainer		2078	0536	Sarstedt	0518		
											
Kapazität / capacity	ml	10	8	4 - 7		8,5 - 10	1,5	2,0	10	15	
Maße / dimensions Ø x L	mm	16 x 80	16 x 81	16 x 75		16 x 100	11 x 38	11 x 38	15 x 102	17 x 100	
Anzahl p. Gestell/number p. frame		4	4	4		4	5	5	4	4	
Anzahl p. Rotor / number p. rotor		16	16	16		16	20	20	16	16	
Drehzahl / speed	RPM	4000	4000	4000		4000	4000	4000	4000	4000	
RZB / RCF		2522	2522	2522		2522	2451	2451	2665	2540	
Radius / radius	mm	141	141	141		141	137	137	149	142	
 (97%)	sec	22	22	22		22	22	22	22	22	
 1	sec	25	25	25		25	25	25	25	25	
 0	sec	110	110	110		110	110	110	110	110	
Probenerwärmung/Sample temp. rise	K <sup>1)</sup>	10	10	10		10	10	10	10	10	











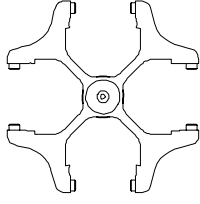

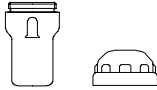



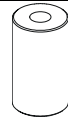



1) Probenerwärmung bei maximaler Drehzahl und 1 Stunde Laufzeit

5) Nach DIN EN 61010, Teil 2 – 020. Die Hinweise für Bio-Sicherheitssysteme in den Kapiteln "Sicherheitshinweise" und "Pflege und Wartung" beachten

1) Sample temp. rise during maximum speed and 1 hour running time

5) in conformity with DIN EN 61010, part 2 – 020. Observe the notes for bio safety systems in chapters "Notes on safety" and "Maintenance and servicing".

1624		1381 + 1382								
<b>Ausschwingrotor 4-fach / Swing out rotor 4-times</b>  		 mit Bioabdichtung / with bio-containment 5)								
		<b>Reduzierung / adapter</b> 1383 								
		<b>Röhrchen / tube</b>								
			0501	Sarstedt						Vacutainer
										
Kapazität / capacity	ml	5	6	7	4,5 - 5,0	2,7 - 3	2,6 - 2,9	4,9	1,6 - 5,0	
Maße / dimensions	Ø x L	mm	12 x 75	12 x 82	12 x 100	11 x 92	11 x 66	13 x 65	13 x 90	13 x 75
Anzahl p. Gestell / number p. frame		5	5	5	5	5	5	5	5	
Anzahl p. Rotor / number p. rotor		20	20	20	20	20	20	20	20	
Drehzahl / speed	RPM	4000	4000	4000	4000	4000	4000	4000	4000	
RZB / RCF		2558	2558	2558	2558	2558	2558	2558	2558	
Radius / radius	mm	143	143	143	143	143	143	143	143	
 (97%)	sec	22	22	22	22	22	22	22	22	
 1	sec	25	25	25	25	25	25	25	25	
 0	sec	110	110	110	110	110	110	110	110	
Probenerwärmung / Sample temp. rise	K <sup>1)</sup>	10	10	10	10	10	10	10	10	











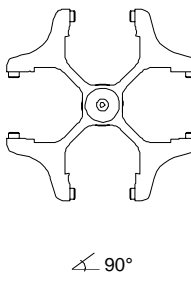
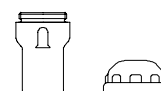









1624		1381 + 1382								
<b>Ausschwingrotor 4-fach / Swing out rotor 4-times</b>  		 mit Bioabdichtung / with bio-containment 5)								
		SK 13.06								
		<b>Reduzierung / adapter</b>								
		1383	1384	1396	6311	6318	1457			
										
<b>Röhrchen / tube</b>										
Vacutainer	0513	0547	0549			Sarstedt	0519			
										
Kapazität / capacity	ml	4,5 - 7	50	85	85	12	50	1,1 - 1,4	25	
Maße / dimensions	Ø x L	mm	13 x 100	29 x 115	38 x 106	38 x 106	17 x 100	29 x 115	8 x 66	24 x 100
Anzahl p. Gestell / number p. frame		5	1	1	1	1	1	7	2	
Anzahl p. Rotor / number p. rotor		20	4	4	4	4	4	28	8	
Drehzahl / speed	RPM	4000	4000	4000	4000	4000	4000	4000	4000	
RZB / RCF		2558	2665	2612	2612	2665	2665	2576	2325	
Radius / radius	mm	143	149	146	146	149	149	144	130	
 (97%)	sec	22	22	22	22	22	22	22	22	
 1	sec	25	25	25	25	25	25	25	25	
 0	sec	110	110	110	110	110	110	110	110	
Probenerwärmung / Sample temp. rise	K <sup>1)</sup>	10	10	10	10	10	10	10	10	











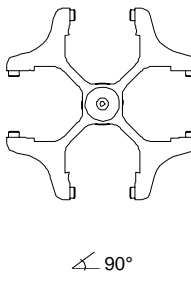









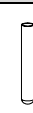
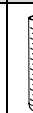

1) Probenerwärmung bei maximaler Drehzahl und 1 Stunde Laufzeit

5) Nach DIN EN 61010, Teil 2 – 020. Die Hinweise für Bio-Sicherheitssysteme in den Kapiteln "Sicherheitshinweise" und "Pflege und Wartung" beachten

1) Sample temp. rise during maximum speed and 1 hour running time

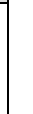
5) in conformity with DIN EN 61010, part 2 – 020. Observe the notes for bio safety systems in chapters "Notes on safety" and "Maintenance and servicing".

1624	1381 + 1382										
<p><b>Ausschwingrotor 4-fach / Swing out rotor 4-times</b></p>  <p>∠ 90°</p>											
	mit Bioabdichtung / with bio-containment 5)										
	<b>Reduzierung / adapter</b>										
		1459	4416	4417	0761	0765	1363	1365			
											
<b>Röhrchen / tube</b>											
	Sarstedt		0546	0545	0526	0534 4)	0535				
											
Kapazität / capacity	ml	4 - 5,5	7,5 - 8,2	50	30	100	30	25	30		
Maße / dimensions	∅ x L	mm	15 x 75	15 x 92	29 x 107	26 x 95	44 x 100	44 x 105	25 x 90	25 x 110	
Anzahl p. Gestell/number p. frame		4	4	1	1	1	1	1	1	1	
Anzahl p. Rotor / number p. rotor		16	16	4	4	4	4	4	4	4	
Drehzahl / speed	RPM	4000	4000	4000	4000	4000	4000	4000	4000	4000	
RZB / RCF		2576	2576	2630	2451	2558	2540	2343	2665		
Radius / radius	mm	144	144	147	137	143	142	131	149		
 (97%)	sec	22	22	22	22	22	22	22	22	22	
 1	sec	25	25	25	25	25	25	25	25	25	
 0	sec	110	110	110	110	110	110	110	110	110	
Probenerwärmung/Sample temp. rise	K <sup>1)</sup>	10	10	10	10	10	10	10	10	10	

1624	1741	1742	1745	1746	1741	1742							
<p><b>Ausschwingrotor 4-fach / Swing out rotor 4-times</b></p>  <p>∠ 90°</p>													
	<b>Reduzierung / adapter</b>												
		0701				0701	0716						
			---	---	---								
	<b>Röhrchen / tube</b>												
	0500	0518	0507	0519	0545	0521	Sarstedt	Sarstedt	Vacutainer	Sarstedt	Sarstedt		
													
Kapazität / capacity	ml	9	15	25	30	50	4,9	1,1 – 1,4	1,6 - 5	4 - 7	4 - 5,5	2,6 - 2,9	
Maße / dimensions	∅ x L	mm	14 x 100	17 x 100	24 x 100	26 x 95	34 x 100	13 x 90	8 x 66	13 x 75	16 x 75	15 x 75	13 x 65
Anzahl p. Gestell/number p. frame		10	7	2	1	10	10	7	7	7	7	7	
Anzahl p. Rotor / number p. rotor		40	28	8	4	40	40	28	28	28	28	28	
Drehzahl / speed	RPM	4000	4000	4000	4000	4000	4000	4000	4000	4000	4000	4000	
RZB / RCF		2415	2451	2451	2451	2451	2451	2415	2325	2325	2325	2325	
Radius / radius	mm	135	137	137	137	137	137	135	130	130	130	130	
 (97%)	sec	22	22	22	22	22	22	22	22	22	22	22	
 1	sec	25	25	25	25	25	25	25	25	25	25	25	
 0	sec	110	110	110	110	110	110	110	110	110	110	110	
Probenerwärmung/Sample temp. rise	K <sup>1)</sup>	10	10	10	10	10	10	10	10	10	10	10	

1) Probenerwärmung bei maximaler Drehzahl und 1 Stunde Laufzeit











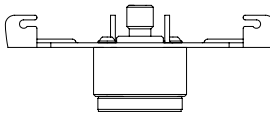



4) nicht mit Stopfen zentrifugierbar, Skal. 10µl-300µl, 15ml, 30ml











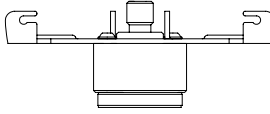



5) Nach DIN EN 61010, Teil 2 – 020. Die Hinweise für Bio-Sicherheitssysteme in den Kapiteln "Sicherheitshinweise" und "Pflege und Wartung" beachten

1) Sample temp. rise during maximum speed and 1 hour running time

4) can not be centrifugated when plug is attached, Scal. 10µl-300µl, 15ml, 30ml

5) in conformity with DIN EN 61010, part 2 – 020. Observe the notes for bio safety systems in chapters "Notes on safety" and "Maintenance and servicing".





1611		1131					1132		
<b>Ausschwingrotor 8-fach / Swing out rotor 8-times</b>  									
		Röhrchen / tube							
		---	0501	Sarstedt	Sarstedt	Vacutainer	2079	Sarstedt	Sarstedt
									
Kapazität / capacity	ml	5	6	2,6 - 2,9	2,7 - 3	1,6 - 5,0	10	4,0 - 5,5	4 - 7
Maße / dimensions	∅ x L mm	12/13 x 75	12 x 82	13 x 65	11 x 66	13 x 75	17 x 70	15 x 75	16 x 75
Anzahl p. Red./number p. adapter		1	1	1	1	1	1	1	1
Anzahl p. Rotor / number p. rotor		8	8	8	8	8	8	8	8
Drehzahl / speed	RPM	4000	4000	4000	4000	4000	4000	4000	4000
RZB / RCF		1914	1914	1914	1914	1914	1914	1914	1914
Radius / radius	mm	107	107	107	107	107	107	107	107
 (97%)	sec	22	22	22	22	22	22	22	22
 1	sec	25	25	25	25	25	25	25	25
 0	sec	104	104	104	104	104	104	104	104
Probenerwärmung/Sample temp. rise	K <sup>1)</sup>	6	6	6	6	6	6	6	6





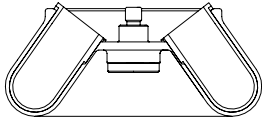
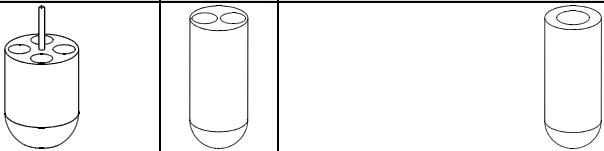
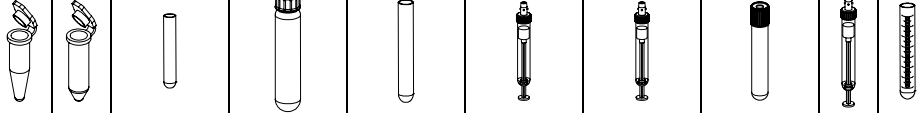

1611		1643				1644			
<b>Ausschwingrotor 8-fach / Swing out rotor 8-times</b>  									
		Röhrchen / tube							
		0578	Vacutainer	---	Sarstedt	0507	Sarstedt	Vacutainer	0518
									
Kapazität / capacity	ml	7	4 - 7	10	4,5 - 5	15	7,5 - 8,2	8,5 - 10	15
Maße / dimensions	∅ x L mm	12 x 100	13 x 100	13 x 100	11 x 92	17 x 100	15 x 92	16 x 100	17 x 100
Anzahl p. Red./number p. adapter		1	1	1	1	1	1	1	1
Anzahl p. Rotor / number p. rotor		8	8	8	8	8	8	8	8
Drehzahl / speed	RPM	4000	4000	4000	4000	4000	4000	4000	4000
RZB / RCF		2415	2415	2415	2415	2415	2415	2415	2415
Radius / radius	mm	135	135	135	135	135	135	135	135
 (97%)	sec	22	22	22	22	22	22	22	22
 1	sec	25	25	25	25	25	25	25	25
 0	sec	104	104	104	104	104	104	104	104
Probenerwärmung/Sample temp. rise	K <sup>1)</sup>	9	9	9	9	9	9	9	9

1) Probenerwärmung bei maximaler Drehzahl und 1 Stunde Laufzeit

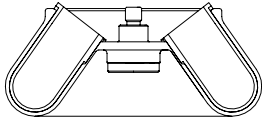
1) Sample temp. rise during maximum speed and 1 hour running time

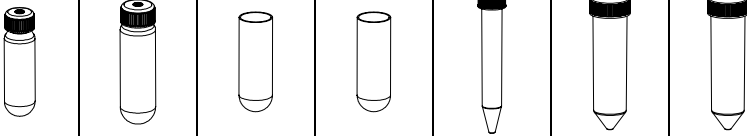









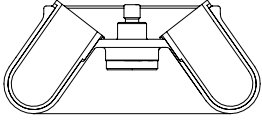

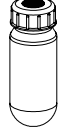









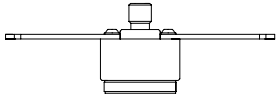

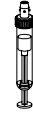

1620A	Reduzierung / adapter										
 <p>Winkelrotor 6-fach / Angle rotor 6-times</p> <p>∠ 35°</p>	1449		1448		1451						
											
	Röhrchen / tube										
	2078	0536	---		0507	Sarstedt	Sarstedt	Vacutainer	Sarstedt	0518	
											
Kapazität / capacity	ml	1,5	2,0	3	10	15	9 - 10	7,5 - 8,2	8,5 - 10	10	15
Maße / dimensions Ø x L	mm	11 x 38	10 x 60	10 x 60	16 x 80	17 x 100	16 x 92	15 x 92	16 x 100	15 x 102	17 x 100
Anzahl p. Red./number p. adapter		4	4	4	2	1	1	1	1	1	1
Anzahl p. Rotor / number p. rotor		24	24	24	12	6	6	6	6	6	6
Drehzahl / speed	RPM	6000	6000	6000	6000	6000	6000	6000	6000	6000	6000
RZB / RCF	<sup>3)</sup>	4065	4065	4065	3904	3904	3904	3904	3904	3904	3904
Radius / radius	mm	101	101	101	97	97	97	97	97	97	97
 (97%)	sec	19	19	19	19	19	19	19	19	19	19
 1	sec	22	22	22	22	22	22	22	22	22	22
 0	sec	104	104	104	104	104	104	104	104	104	104
Probenerwärmung/Sample temp. rise	K <sup>1)</sup>	5	5	5	5	5	5	5	5	5	5

1620A	Reduzierung / adapter						Einsatz / insert					
 <p>Winkelrotor 6-fach / Angle rotor 6-times</p> <p>∠ 35°</p>	1447		1446		1463		1466		1454		1646	
											Falcon-Set für 6 Röhrchen / Falcon-set for 6 tubes	
	Röhrchen / tube											
	0545	0546	0548	0521	0509	0513	0513					
												
Kapazität / capacity	ml	30	50	75	50	15	50	50				
Maße / dimensions Ø x L	mm	26 x 95	29 x 107	35 x 105	34 x 100	17 x 120	29 x 115	29 x 115				
Anzahl p. Red./number p. adapter		1	1	1	1	1	1	1				
Anzahl p. Rotor / number p. rotor		6	6	6	6	6	6	6				
Drehzahl / speed	RPM	6000	6000	6000	6000	6000	6000	6000				
RZB / RCF	<sup>3)</sup>	3824	4025	4146	4146	3985	3985	3985				
Radius / radius	mm	95	100	103	103	99	99	99				
 (97%)	sec	19	19	19	19	19	19	19				
 1	sec	22	22	22	22	22	22	22				
 0	sec	104	104	104	104	104	104	104				
Probenerwärmung/Sample temp. rise	K <sup>1)</sup>	5	5	5	5	5	5	5				

1) Probenerwärmung bei maximaler Drehzahl und 1 Stunde Laufzeit  
 3) Zentrifugiergefäße aus Glas nur belastbar bis RZB 4000









1) Sample temp. rise during maximum speed and 1 hour running time  
 3) Centrifuge containers of glass will not stand RCF values exceeding 4000

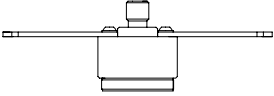







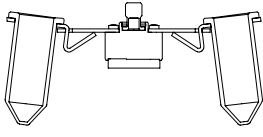
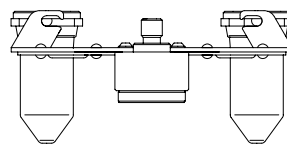

1620A		Reduzierung / adapter						
<b>Winkelrotor 6-fach / Angle rotor 6-times</b>  		SK 63.08						
		Röhrchen / tube						
		0547	0549		0501	Vacutainer	Sarstedt	
								
Kapazität / capacity	ml	85	85	5	6	1,6 - 5	2,6 - 2,9	
Maße / dimensions	Ø x L	mm	38 x 106	38 x 106	12/13 x 75	12 x 82	13 x 75	13 x 65
Anzahl p. Red./number p. adapter		1	1	2	2	2	2	
Anzahl p. Rotor / number p. rotor		6	6	12	12	12	12	
Drehzahl / speed	RPM	6000	6000	6000	6000	6000	6000	
RZB / RCF	<sup>3)</sup>	4186	4186	3783	3783	3783	3783	
Radius / radius	mm	104	104	94	94	94	94	
 (97%)	sec	19	19	19	19	19	19	
 1	sec	22	22	22	22	22	22	
 0	sec	104	104	104	104	104	104	
Probenerwärmung/Sample temp. rise	K <sup>1)</sup>	5	5	5	5	5	5	

1628		1122			1621				
<b>Ausschwingrotor 12-fach / Swing out rotor 12-times</b>   mit / with 1122  mit / with 1621									
		Reduzierung / adapter							
		Röhrchen / tube							
		2079	Sarstedt	Vacutainer	0507	Sarstedt	Vacutainer	0518	
									
Kapazität / capacity	ml	10	4 - 5,5	4 - 7	15	7,5 - 8,2	8,5 - 10	15	
Maße / dimensions	Ø x L	mm	17 x 70	15 x 75	16 x 75	17 x 100	15 x 92	16 x 100	17 x 100
Anzahl p. Gestell/number p. frame		1	1	1	1	1	1	1	
Anzahl p. Rotor / number p. rotor		12	12	12	12	12	12	12	
Drehzahl / speed	RPM	4000	4000	4000	4000	4000	4000	4000	
RZB / RCF		2254	2254	2254	2683	2683	2683	2683	
Radius / radius	mm	126	126	126	150	150	150	150	
 (97%)	sec	22	22	22	22	22	22	22	
 1	sec	25	25	25	25	25	25	25	
 0	sec	110	110	110	110	110	110	110	
Probenerwärmung/Sample temp. rise	K <sup>1)</sup>	12	12	12	16	16	16	16	

1) Probenerwärmung bei maximaler Drehzahl und 1 Stunde Laufzeit  
 3) Zentrifugiergefäße aus Glas nur belastbar bis RZB 4000









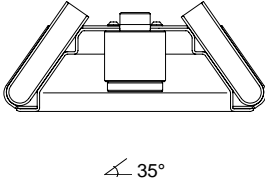
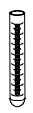

1) Sample temp. rise during maximum speed and 1 hour running time  
 3) Centrifuge containers of glass will not stand RCF values exceeding 4000





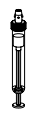



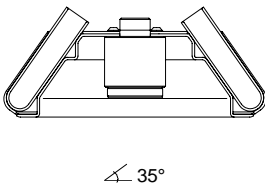

1628		1127							
<b>Ausschwingrotor 12-fach / Swing out rotor 12-times</b>    ↙ 55° mit / with 1127									
		<b>Reduzierung / adapter</b>							
		<b>Röhrchen / tube</b>							
			Vacutainer	Sarstedt	Sarstedt				
									
Kapazität / capacity	ml	5	1,6 – 5,0	2,6 – 2,9	2,7 - 3				
Maße / dimensions Ø x L	mm	12 / 13 x 75	13 x 75	13 x 65	11 x 66				
Anzahl p. Gestell/number p. frame		1	1	1	1				
Anzahl p. Rotor / number p. rotor		12	12	12	12				
Drehzahl / speed	RPM	4000	4000	4000	4000				
RZB / RCF		2236	2236	2236	2236				
Radius / radius	mm	125	125	125	125				
 (97%)	sec	22	22	22	22				
 1	sec	25	25	25	25				
 0	sec	110	110	110	110				
Probenerwärmung/Sample temp. rise	K <sup>1)</sup>	12	12	12	12				

1617		1619								
<b>Ausschwingrotor 8-fach / Swing out rotor 8-times</b>    ↙ 45°		  ↙ 90°				1681				
		<b>Reduzierung / adapter</b>								
		1462-A				<b>Reduzierung / adapter</b>				
		<b>Röhrchen / tube</b>				<b>Röhrchen / tube</b>				
		0509	0513			0509	0513			
										
Kapazität / capacity	ml	15	50	Kapazität / capacity	ml	15	50			
Maße / dimensions Ø x L	mm	17 x 120	29 x 115	Maße / dimensions Ø x L	mm	17 x 120	29 x 115			
Anzahl p. Gestell/number p. frame		1	1	Anzahl p. Gestell/number p. frame		1	1			
Anzahl p. Rotor / number p. rotor		8	8	Anzahl p. Rotor / number p. rotor		6	6			
Drehzahl / speed	RPM	4000	4000	Drehzahl / speed	RPM	4000	4000			
RZB / RCF		2469	2469	RZB / RCF		2701	2701			
Radius / radius	mm	138	138	Radius / radius	mm	151	151			
 (97%)	sec	22	22	 (97%)	sec	22	22			
 1	sec	25	25	 1	sec	25	25			
 0	sec	110	110	 0	sec	110	110			
Probenerwärmung/Sample temp. rise	K <sup>1)</sup>	11	11	Probenerwärmung/Sample temp. rise	K <sup>1)</sup>	10	10			

1) Probenerwärmung bei maximaler Drehzahl und 1 Stunde Laufzeit

1) Sample temp. rise during maximum speed and 1 hour running time



1613		Reduzierung / adapter								
<b>Winkelrotor 12-fach / Angle rotor 12-times</b>  35°										
		Röhrchen / tube								
		0518	0507	0509	Vacutainer	Sarstedt				
										
Kapazität / capacity	ml	15	15	15	4 - 7	4,9	4,5 - 5	7,5 - 8,2	9 - 10	
Maße / dimensions	∅ x L	mm	17 x 100	17 x 100	17 x 120	13 x 100	13 x 90	11 x 92	15 x 92	16 x 92
Anzahl p. Red./number p. adapter		1	1	1	1	1	1	1	1	
Anzahl p. Rotor / number p. rotor		12	12	6	12	12	12	12	12	
Drehzahl / speed	RPM	6000	6000	6000	6000	6000	6000	6000	6000	
RZB / RCF	<sup>3)</sup>	4146	4146	4146	4146	4146	4146	4146	4146	
Radius / radius	mm	103	103	103	103	103	103	103	103	
 (97%)	sec	13	13	13	13	13	13	13	13	
 1	sec	15	15	15	15	15	15	15	15	
 0	sec	104	104	104	104	104	104	104	104	
Probenerwärmung/Sample temp. rise	K <sup>1)</sup>	5	5	5	5	5	5	5	5	

1613		Reduzierung / adapter								
<b>Winkelrotor 12-fach / Angle rotor 12-times</b>  35°		1054-A								
		Röhrchen / tube								
		Sarstedt	Vacutainer	Vacutainer		0501	Sarstedt	Sarstedt	Sarstedt	
										
Kapazität / capacity	ml	10	8	8,5 - 10	5	6	1,1 - 1,4	2,7 - 3	2,6 - 2,9	
Maße / dimensions	∅ x L	mm	15 x 102	16 x 125	16 x 100	12/13 x 75	12 x 82	8 x 66	11 x 66	13 x 65
Anzahl p. Red./number p. adapter		1	1	1	1	1	1	1	1	
Anzahl p. Rotor / number p. rotor		12	6	12	12	12	12	12	12	
Drehzahl / speed	RPM	6000	6000	6000	6000	6000	6000	6000	6000	
RZB / RCF	<sup>3)</sup>	4146	4146	4146	3300	3300	3300	3300	3300	
Radius / radius	mm	103	103	103	82	82	82	82	82	
 (97%)	sec	13	13	13	13	13	13	13	13	
 1	sec	15	15	15	15	15	15	15	15	
 0	sec	104	104	104	104	104	104	104	104	
Probenerwärmung/Sample temp. rise	K <sup>1)</sup>	5	5	5	5	5	5	5	5	

1) Probenerwärmung bei maximaler Drehzahl und 1 Stunde Laufzeit  
 3) Zentrifugiergefäße aus Glas nur belastbar bis RZB 4000

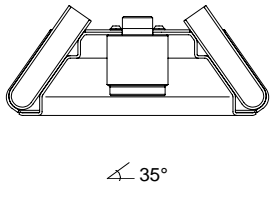

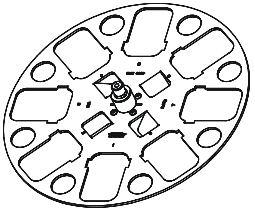







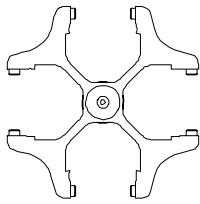
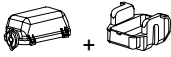

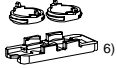

1) Sample temp. rise during maximum speed and 1 hour running time  
 3) Centrifuge containers of glass will not stand RCF values exceeding 4000











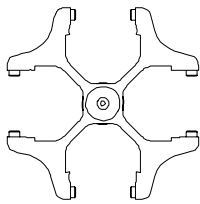
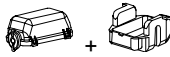

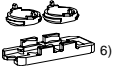

1613		Reduzierung / adapter											
<b>Winkelrotor 12-fach / Angle rotor 12-times</b>  35°		1054-A		0701		6305		SK 1/89		SK 19/85-4		SK 73/74	
		Röhrchen / tube											
		Vacutainer				Sarstedt	Vacutainer	2078	0536				
Kapazität / capacity	ml	1,6 - 5	4	4	0,8	4 - 5,5	4 - 7	1,5	2				
Maße / dimensions	Ø x L	mm	13 x 75	12 x 60	10 x 88	8 x 45	15 x 75	16 x 75	11 x 38	11 x 38			
Anzahl p. Red./number p. adapter		1	1	1	1	1	1	1	1				
Anzahl p. Rotor / number p. rotor		12	12	12	12	12	12	12	12				
Drehzahl / speed	RPM	6000	6000	6000	6000	6000	6000	6000	6000				
RZB / RCF		3300	3260	3502	2576	3663	3663	2737	2737				
Radius / radius	mm	82	81	87	64	91	91	68	68				
(97%)	sec	13	13	13	13	13	13	13	13				
1	sec	15	15	15	15	15	15	15	15				
0	sec	104	104	104	104	104	104	104	104				
Probenerwärmung/Sample temp. rise	K <sup>1)</sup>	5	5	5	5	5	5	5	5				

1418		1467			1468				
<b>Winkelrotor 8-fach / Angle rotor 8-times</b>  45°									
		0716		E2109	E2110				
		Röhrchen / tube							
0507	0518	---	0509	0513	0546	---			
Kapazität / capacity	ml	15	15	12	15	50	50	50	
Maße / dimensions	Ø x L	mm	17 x 100	17 x 100	17 x 100	17 x 120	29 x 115	29 x 107	29 x 115
Anzahl p. Gestell/number p. frame		4	4	4	4	1	1	1	
Anzahl p. Rotor / number p. rotor		32	32	32	32	8	8	8	
Drehzahl / speed	RPM	4000	4000	4000	4000	4000	4000	4000	
RZB / RCF		2540	2540	2540	2594	2486	2486	2486	
Radius / radius	mm	142	142	142	145	139	139	139	
(97%)	sec	36	36	36	36	36	36	36	
1	sec	43	43	43	43	43	43	43	
0	sec	200	200	200	200	200	200	200	
Probenerwärmung/Sample temp. rise	K <sup>1)</sup>	16	16	16	16	16	16	16	

1) Probenerwärmung bei maximaler Drehzahl und 1 Stunde Laufzeit







1) Sample temp. rise during maximum speed and 1 hour running time



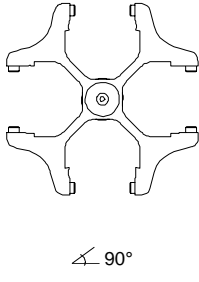
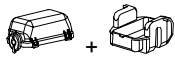







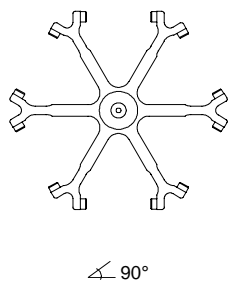

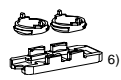

1624	1661 + 1660							
<p><b>Ausschwingrotor 4-fach / Swing out rotor 4-times</b></p>  <p>∠ 90°</p>								
	<b>Spannplatte / slide carrier</b>							
	1662				1670			
								
	<b>Zyto-Kammer / cyto chamber</b>							
	1663	1664	1665	1666	1667	1668	1663	1664
								
Kapazität / capacity ml	1	2	4	8	3 x 2	4 x 1	1	2
Maße / dimensions Ø / A mm <sup>2</sup>	6,2 / 30	8,7 / 60	12,4 / 120	17,5 / 240	8,7 / 60	6,2 / 30	6,2 / 30	8,7 / 60
Anzahl p. Gestell / number p. frame	1	1	1	1	1	1	2	2
Anzahl p. Rotor / number p. rotor	4	4	4	4	4	4	8	8
Filterkarten / filter cards	1675	1675	1675	1676	1677	1678	1692	1692
Drehzahl / speed RPM	4000	4000	4000	4000	4000	4000	4000	4000
RZB / RCF	1646	1646	1646	1646	1646	1646	1646	1646
Radius / radius mm	92	92	92	92	92	92	92	92
 (97%) sec	22	22	22	22	22	22	22	22
 1 sec	25	25	25	25	25	25	25	25
 0 sec	110	110	110	110	110	110	110	110
Probenerwärmung / Sample temp. rise K <sup>1)</sup>	10	10	10	10	10	10	10	10

1624	1661 + 1660				1660	1680		
<p><b>Ausschwingrotor 4-fach / Swing out rotor 4-times</b></p>  <p>∠ 90°</p>								
	<b>Spannplatte / slide carrier</b>				<b>1285</b>	<b>Spannplatte / slide carrier</b>		
	1670				1285	1662		
					 <p>nur ohne Deckel / without lid 1661</p>			
	<b>Zyto-Kammer / cyto chamber</b>				<b>Zyto-Kammer / cyto chamber</b>	<b>Zyto-Kammer / cyto chamber</b>		
	1665	1666	1667	1668		1671	1672	1673
								
Kapazität / capacity ml	4	8	3 x 2	4 x 1	Objektträger / object slide	[1] 0,5	[1] 0,5	[1] 0,5
Maße / dimensions Ø / A mm <sup>2</sup>	12,4 / 120	17,5 / 240	8,7 / 60	6,2 / 30	26 / 76	6,2 / 30	8,7 / 60	12,4 / 120
Anzahl p. Gestell / number p. frame	2	2	2	2	6	1	1	1
Anzahl p. Rotor / number p. rotor	8	8	8	8	24	4	4	4
Filterkarten / filter cards	1692	1691	1694	1693		[1] 1696	[1] 1697	[1] 1698
Drehzahl / speed RPM	4000	4000	4000	4000	4000	4000	4000	4000
RZB / RCF	1646	1646	1646	1646	1574	1467	1467	1467
Radius / radius mm	92	92	92	92	88	82	82	82
 (97%) sec	22	22	22	22	22	22	22	22
 1 sec	25	25	25	25	25	25	25	25
 0 sec	110	110	110	110	110	110	110	110
Probenerwärmung / Sample temp. rise K <sup>1)</sup>	10	10	10	10	10	6	6	6

1) Probenerwärmung bei maximaler Drehzahl und 1 Stunde Laufzeit  
 6) Objektträger nur belastbar bis RZB 1100  
 [1] Einschritt-Methode











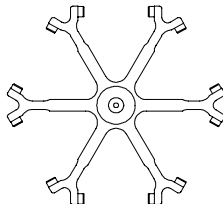

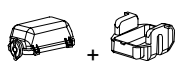

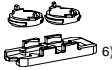
1) Sample temp. rise during maximum speed and 1 hour running time  
 6) Object slide will not stand RCF values exceeding 1100  
 [1] One-step method











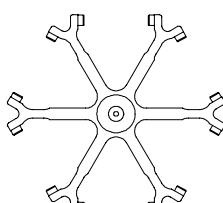

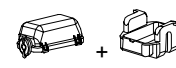
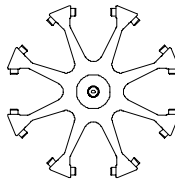



1624		1661 + 1660							
<b>Ausschwingrotor 4-fach / Swing out rotor 4-times</b>   90°									
		<b>Spannplatte / slide carrier</b>							
		1470							
									
<b>Kapazität / capacity</b> ml <b>Maße / dimensions</b> Ø / A mm <sup>2</sup> <b>Anzahl p. Gestell / number p. frame</b> <b>Anzahl p. Rotor / number p. rotor</b> <b>Filterkarten / filter cards</b> <b>Drehzahl / speed</b> RPM <b>RZB / RCF</b> <b>Radius / radius</b> mm  (97%) sec  1 sec  0 sec <b>Probenerwärmung / Sample temp. rise</b> K <sup>1)</sup>		1471		1475					
									
		1 x 8		2 x 8					
		17,5 / 240		17,5 / 240					
		1		1					
		4		4					
		---		---					
		4000		4000					
1556		1556							
87		87							
22		22							
25		25							
110		110							
10		10							

1626		1661 + 1660															
<b>Ausschwingrotor 6-fach / Swing out rotor 6-times</b>   90°																	
		<b>Spannplatte / slide carrier</b>															
		1662				1670											
																	
<b>Kapazität / capacity</b> ml <b>Maße / dimensions</b> Ø / A mm <sup>2</sup> <b>Anzahl p. Gestell / number p. frame</b> <b>Anzahl p. Rotor / number p. rotor</b> <b>Filterkarten / filter cards</b> <b>Drehzahl / speed</b> RPM <b>RZB / RCF</b> <b>Radius / radius</b> mm  (97%) sec  1 sec  0 sec <b>Probenerwärmung / Sample temp. rise</b> K <sup>1)</sup>		1663		1664		1665		1666		1667		1668		1663		1664	
																	
		1		2		4		8		3 x 2		4 x 1		1		2	
		6,2 / 30		8,7 / 60		12,4 / 120		17,5 / 240		8,7 / 60		6,2 / 30		6,2 / 30		8,7 / 60	
		1		1		1		1		1		1		2		2	
		6		6		6		6		6		6		12		12	
		1675		1675		1675		1676		1677		1678		1692		1692	
		4000		4000		4000		4000		4000		4000		4000		4000	
		2039		2039		2039		2039		2039		2039		2039		2039	
		114		114		114		114		114		114		114		114	
22		22		22		22		22		22		22		22			
25		25		25		25		25		25		25		25			
110		110		110		110		110		110		110		110			
8		8		8		8		8		8		8		8			

1) Probenerwärmung bei maximaler Drehzahl und 1 Stunde Laufzeit  
 6) Objektträger nur belastbar bis RZB 1100

1) Sample temp. rise during maximum speed and 1 hour running time  
 6) Object slide will not stand RCF values exceeding 1100

1626		1661 + 1660				1660	1680					
<b>Ausschwingrotor 6-fach / Swing out rotor 6-times</b>    												
		<b>Spannplatte / slide carrier</b>					<b>Spannplatte / slide carrier</b>					
		<b>1670</b>					<b>1285</b>					
							 nur ohne Deckel / without lid 1661					
		<b>Zyto-Kammer / cyto chamber</b>					<b>Zyto-Kammer / cyto chamber</b>					
		<b>1665</b>		<b>1666</b>		<b>1667</b>		<b>1668</b>				
												
Kapazität / capacity	ml	4	8	3 x 2	4 x 1	Objektträger/ object slide	[1] 0,5	[1] 0,5	[1] 0,5			
Maße / dimensions Ø / A	mm <sup>2</sup>	12,4 / 120	17,5 / 240	8,7 / 60	6,2 / 30	26 / 76	6,2 / 30	8,7 / 60	12,4 / 120			
Anzahl p. Gestell/number p. frame		2	2	2	2	6	1	1	1			
Anzahl p. Rotor / number p. rotor		12	12	12	12	36	6	6	6			
Filterkarten / filter cards		1692	1691	1694	1693		[1] 1696	[1] 1697	[1] 1698			
Drehzahl / speed	RPM	4000	4000	4000	4000	4000	4000	4000	4000			
RZB / RCF		2039	2039	2039	2039	1914	1842	1842	1842			
Radius / radius	mm	114	114	114	114	107	103	103	103			
 (97%)	sec	22	22	22	22	22	22	22	22			
 1	sec	25	25	25	25	25	25	25	25			
 0	sec	110	110	110	110	110	110	110	110			
Probenerwärmung/Sample temp. rise	K <sup>1)</sup>	8	8	8	8	8	8	8	8			

1626		1661 + 1660		1648		1680		
<b>Ausschwingrotor 6-fach / Swing out rotor 6-times</b>    				<b>Ausschwingrotor 8-fach / Swing out rotor 8-times</b>    				
		<b>Spannplatte / slide carrier</b>				<b>Spannplatte / slide carrier</b>		
		<b>1470</b>				<b>1662</b>		
								
		<b>Zyto-Kammer / cyto chamber</b>				<b>Zyto-Kammer / cyto chamber</b>		
		<b>1471</b>	<b>1475</b>			<b>1671</b>	<b>1672</b>	<b>1673</b>
								
Kapazität / capacity	ml	1 x 8	2 x 8	Kapazität / capacity	ml	[1] 0,5	[1] 0,5	[1] 0,5
Maße / dimensions Ø x L	mm	17,5 / 240	17,5 / 240	Maße / dimensions Ø x L	mm	6,2 / 30	8,7 / 60	12,4 / 120
Anzahl p. Gehänge/number p. hanger		1	1	Anzahl p. Gehänge/number p. hanger		1	1	1
Anzahl p. Rotor / number p. rotor		6	6	Anzahl p. Rotor / number p. rotor		8	8	8
Filterkarten / filter cards		---	---	Filterkarten / filter cards		[1] 1696	[1] 1697	[1] 1698
Drehzahl / speed	RPM	4000	4000	Drehzahl / speed	RPM	4000	4000	4000
RZB / RCF		1950	1950	RZB / RCF		2218	2218	2218
Radius / radius	mm	109	109	Radius / radius	mm	124	124	124
 (97%)	sec	22	22	 (97%)	sec	22	22	22
 1	sec	25	25	 1	sec	28	28	28
 0	sec	110	110	 0	sec	117	117	117
Probenerwärmung/Sample temp. rise	K <sup>1)</sup>	8	8	Probenerwärmung/Sample temp. rise	K <sup>1)</sup>	13	13	13

1) Probenerwärmung bei maximaler Drehzahl und 1 Stunde Laufzeit  
 6) Objektträger nur belastbar bis RZB 1100  
 [1] Einschritt-Methode

1) Sample temp. rise during maximum speed and 1 hour running time  
 6) Object slide will not stand RCF values exceeding 1100  
 [1] One-step method